

---

## 4.2

# Viscoelasticity

---

# Viscoelasticity

- elastic solids (e.g. metals, ceramics) obey Hooke's law:  $\sigma = E\epsilon$
- the elastic modulus is independent of time  $t$  and strain rate  $d\epsilon/dt$  (as long as  $T$  is moderate)

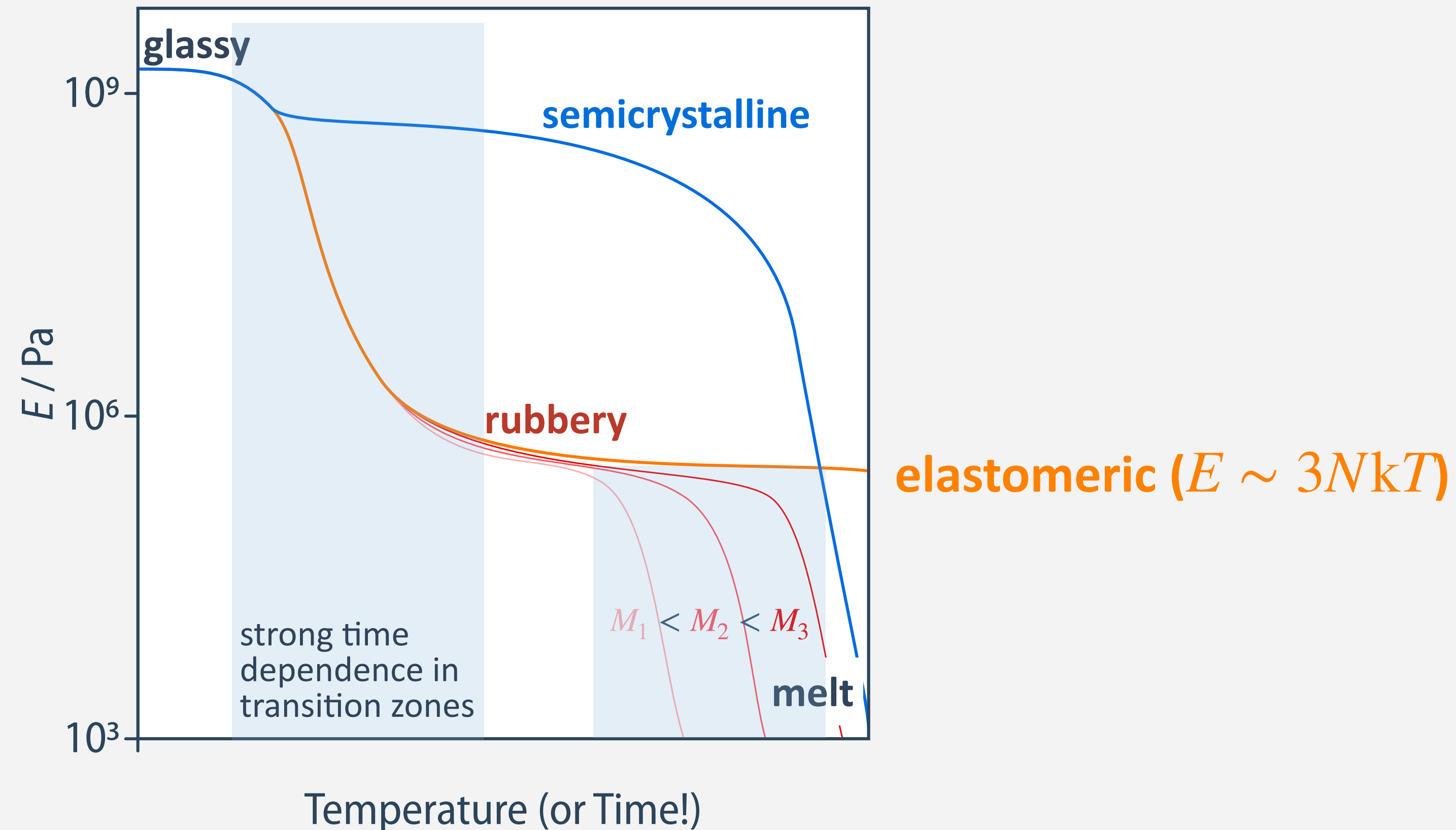

- in contrast, polymer response depends strongly on time and strain rate, especially near transitions

# Example - Silly Putty

- silly putty exhibits different mechanical behavior depending on the time-scale of deformation

**elastic solid**

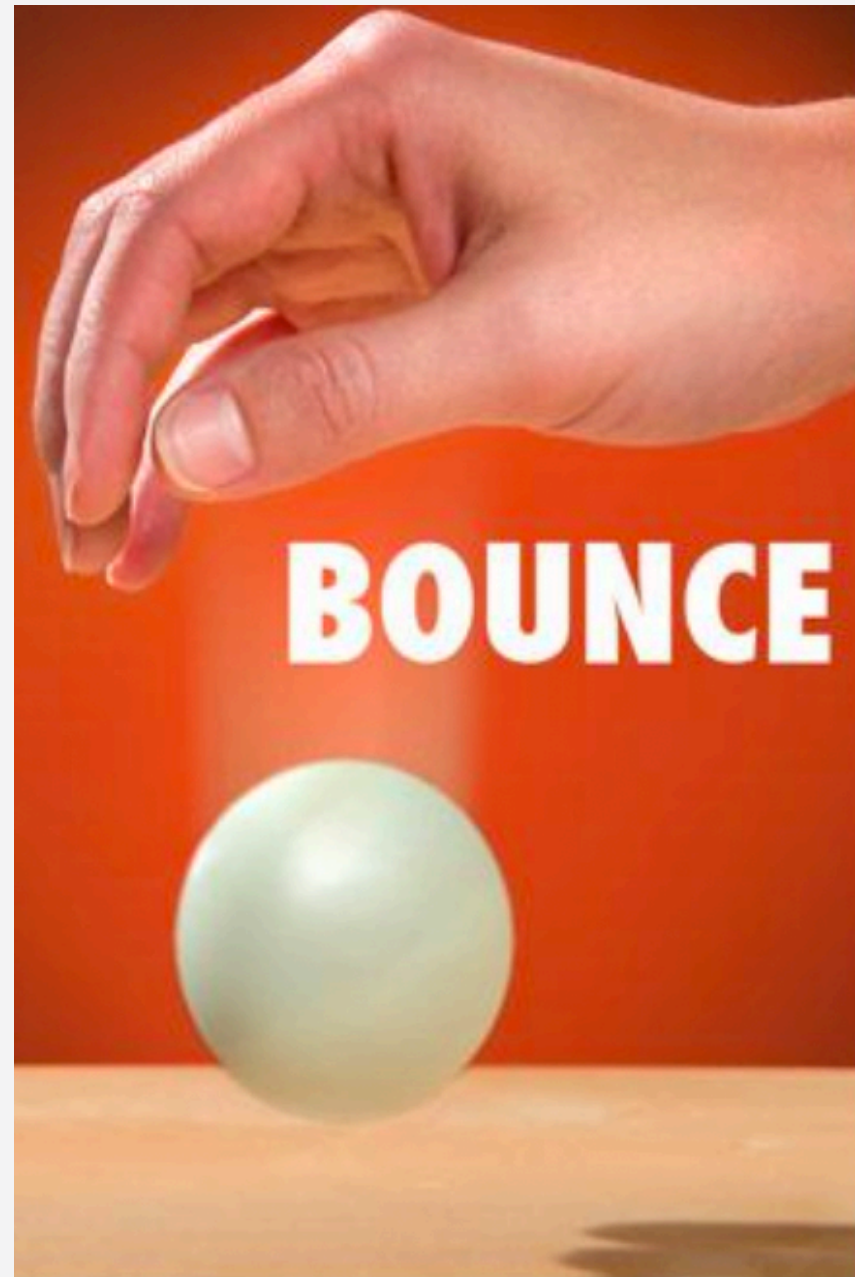

**short time scales**

**deformability**

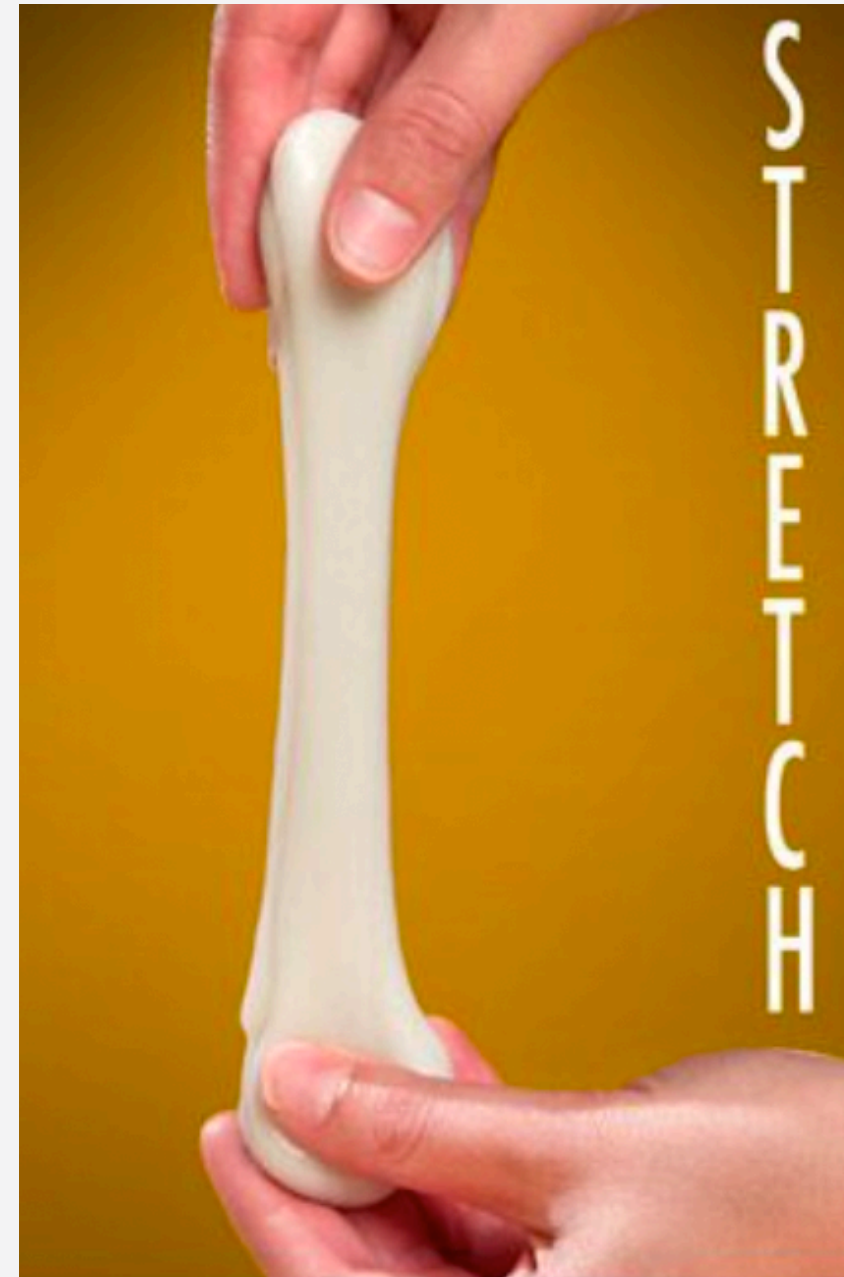

**“fast” strain rate**

**liquid flow**



**long time scales**

- elastic behavior dominates at short deformation times (high frequency)
- flow behavior dominates at long deformation times (low frequency)

# Time-Dependent Viscoelastic Behavior of Silly Putty

- networks from transiently cross-linked poly(dimethoxysiloxane) (PDMS):

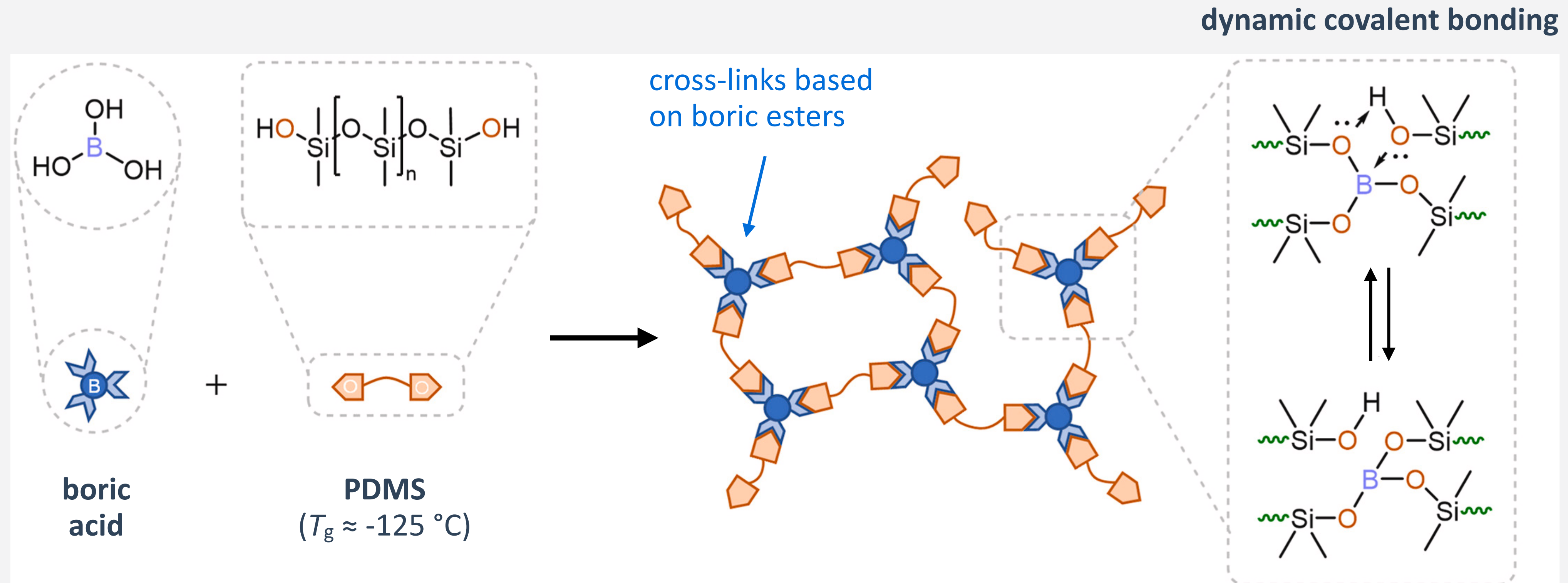

- dynamic boronic ester bonds allow the network to flow upon bond exchange or dissociation

# Importance of Viscoelasticity

- time, frequency, and temperature jointly determine polymer performance and processing behavior

## long-term properties

(creep, fatigue)

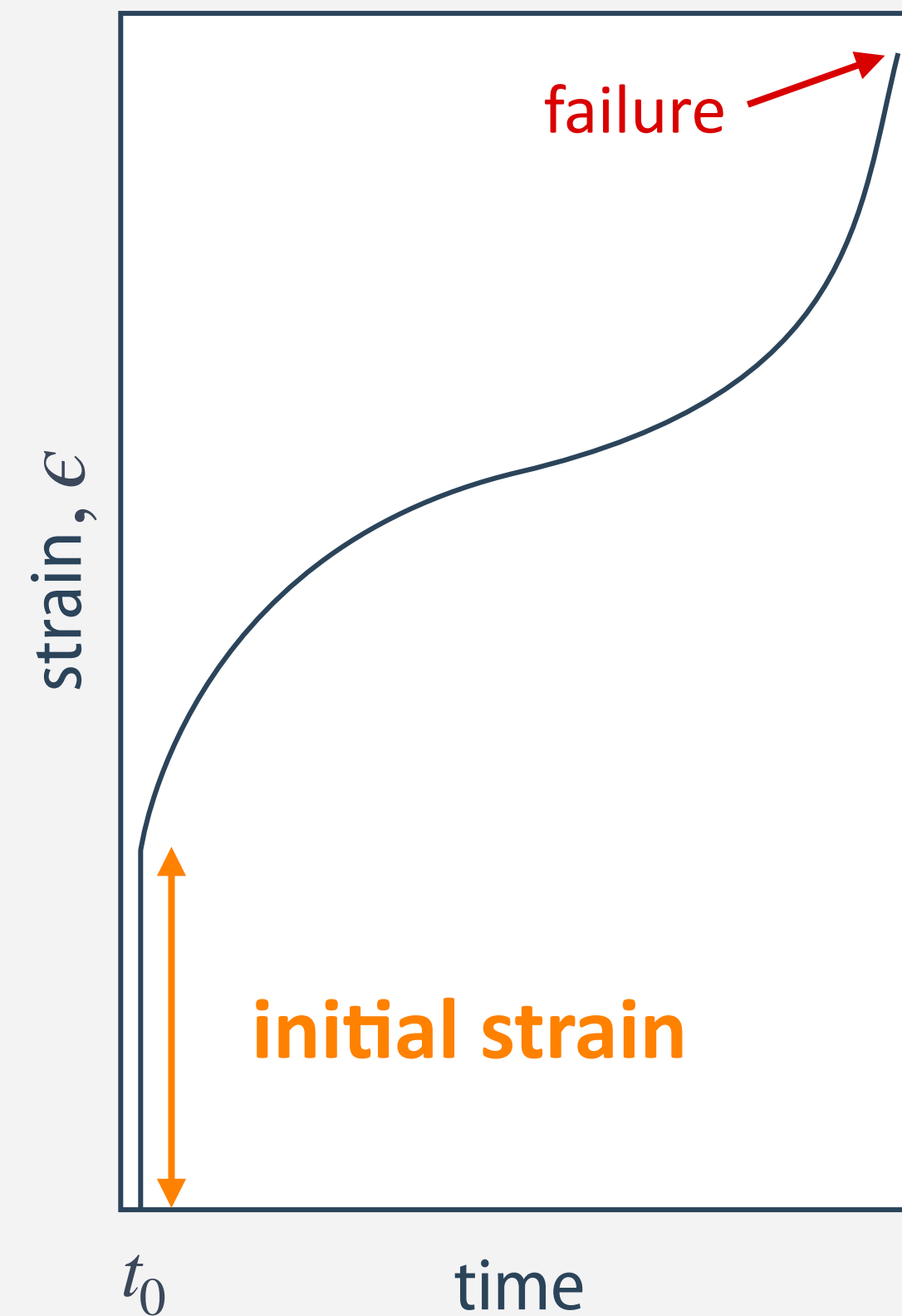

## short-term properties

(impact resistance, energy dissipation, vibration,...)



## processability

( e.g. thermoforming, fiber drawing)

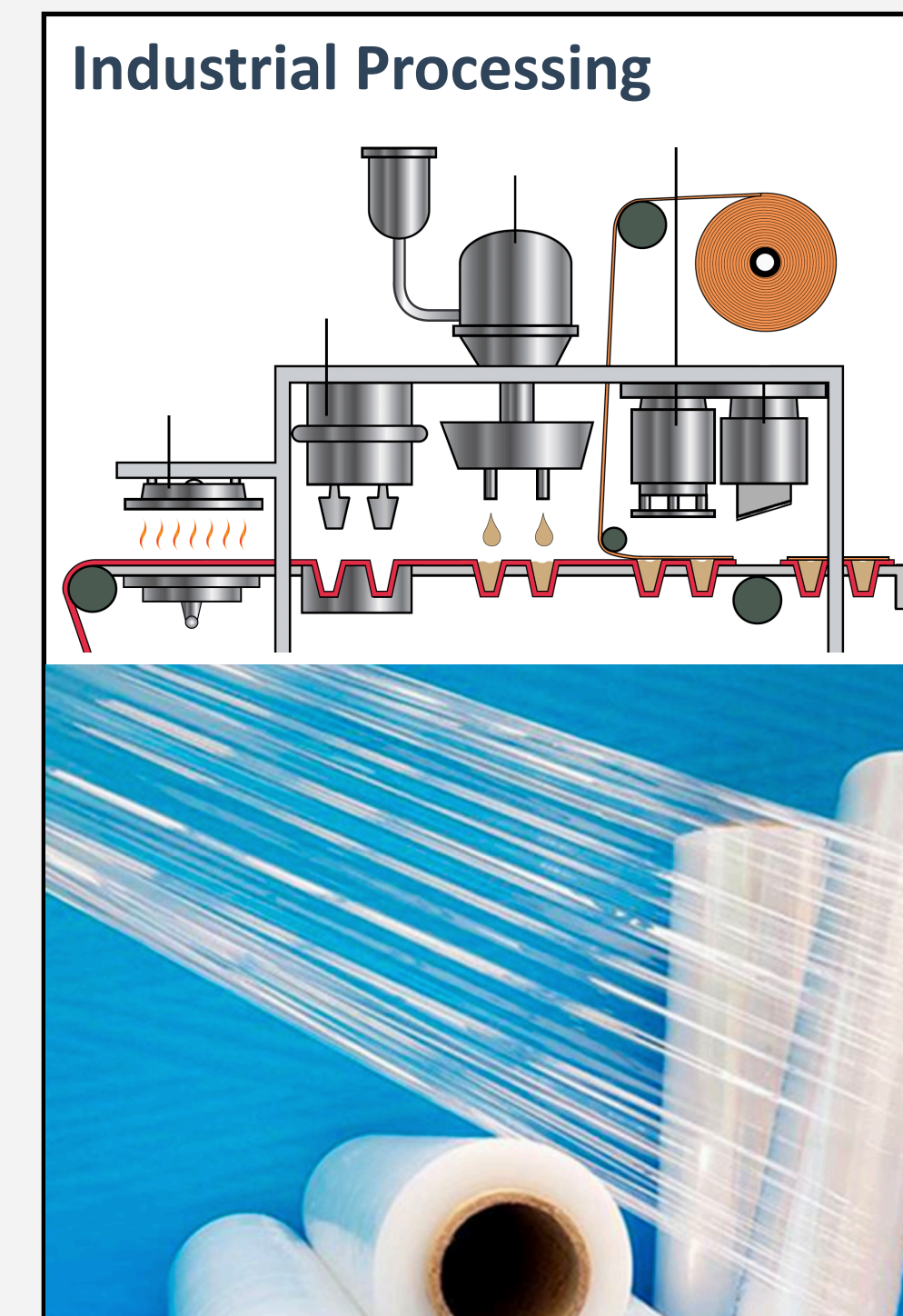

# Elastic, Viscoelastic, and Viscous Responses

- creep tests illustrate the intermediate, time-dependent behavior of viscoelastic materials

**elastic solid**

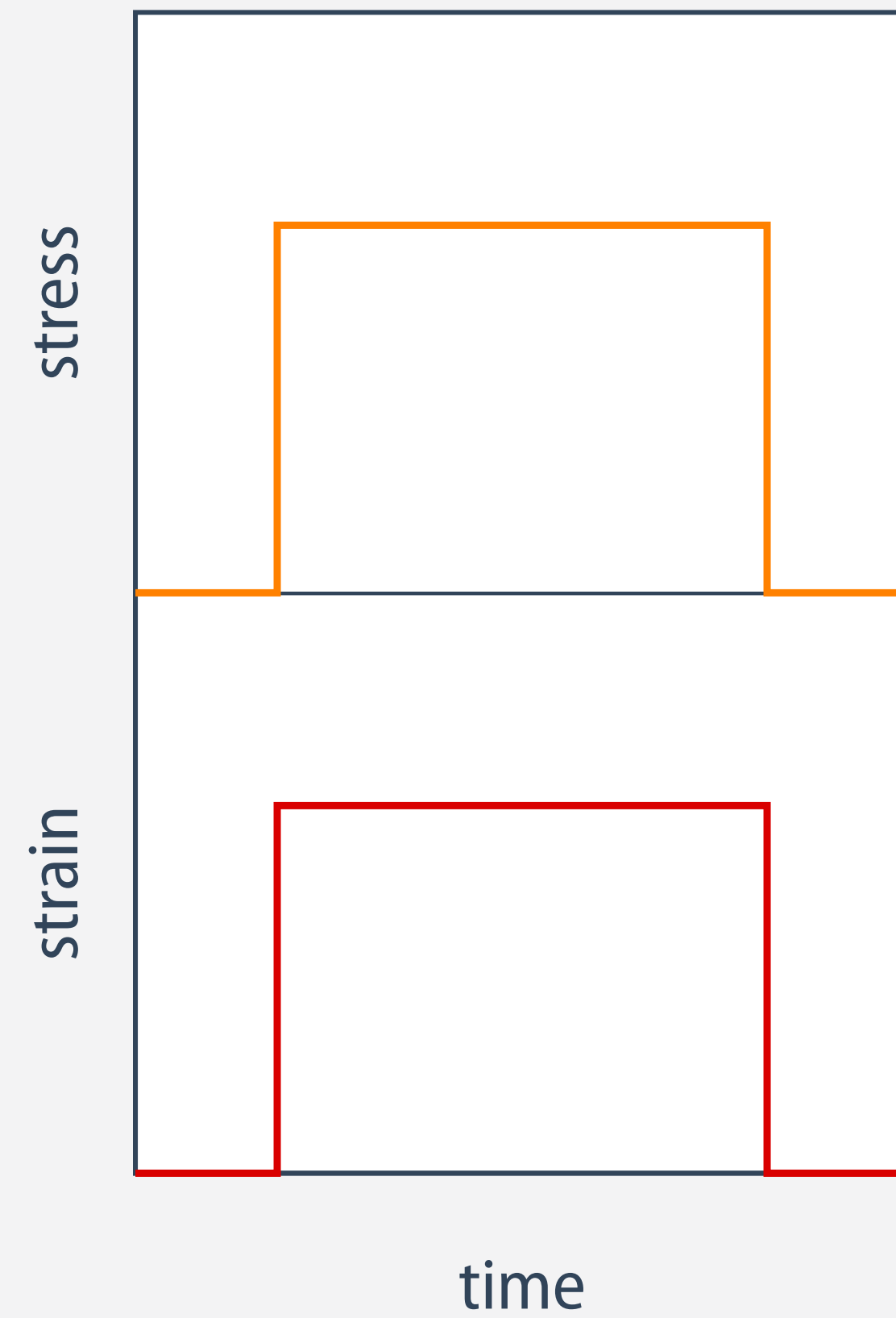

**viscoelastic**

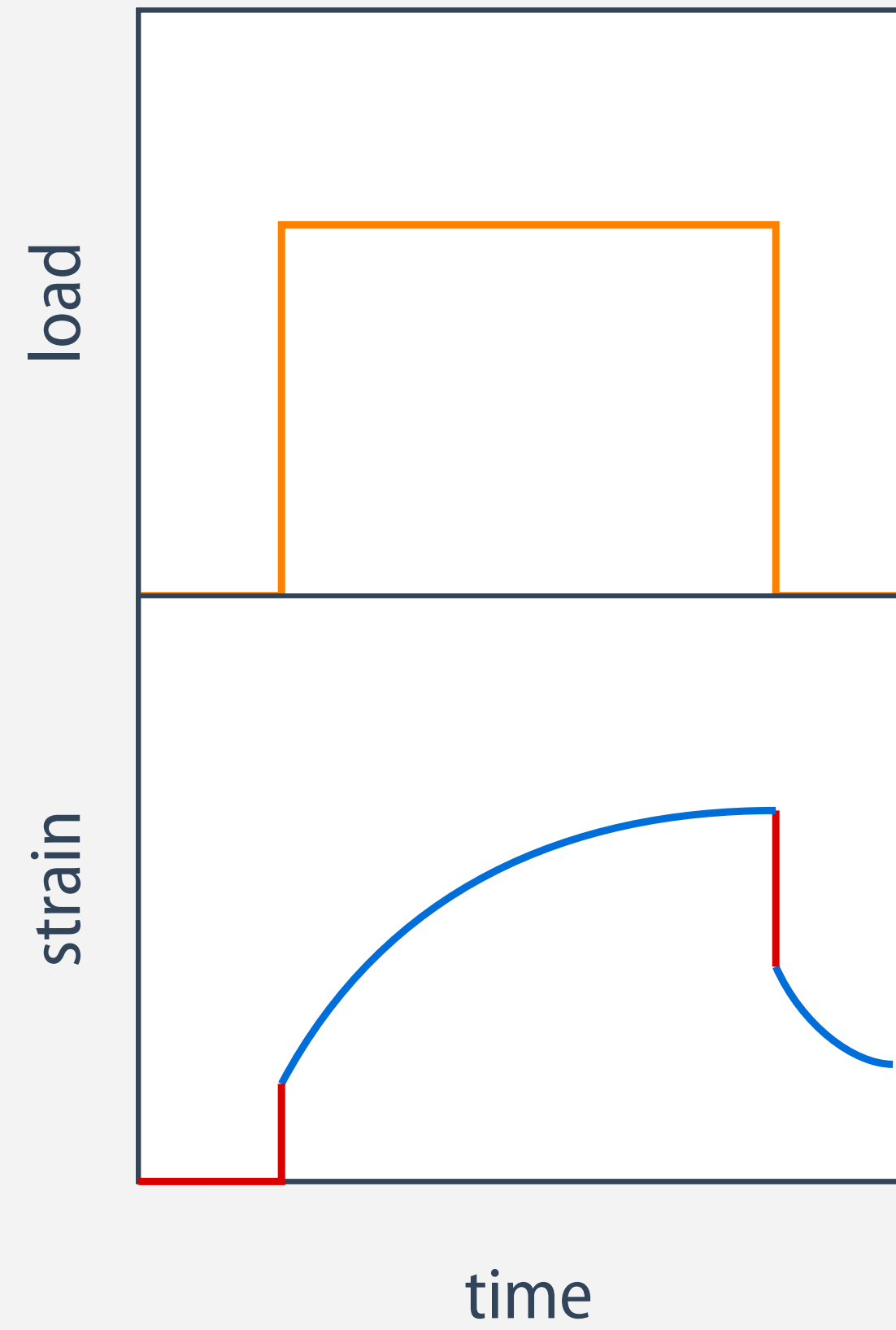

**liquid flow**

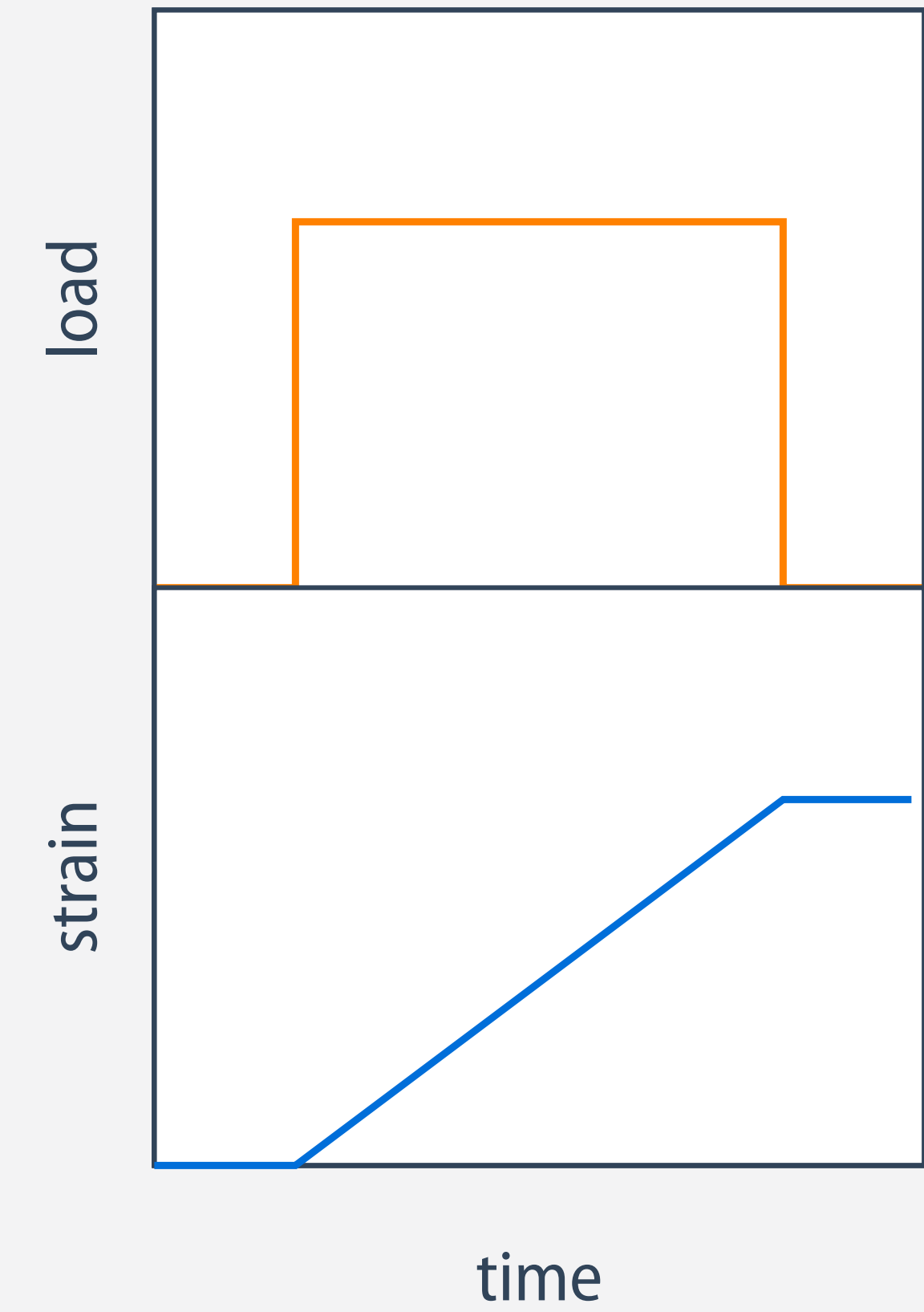

# Phenomenological Description of Viscoelasticity

**creep**  
(constant stress)

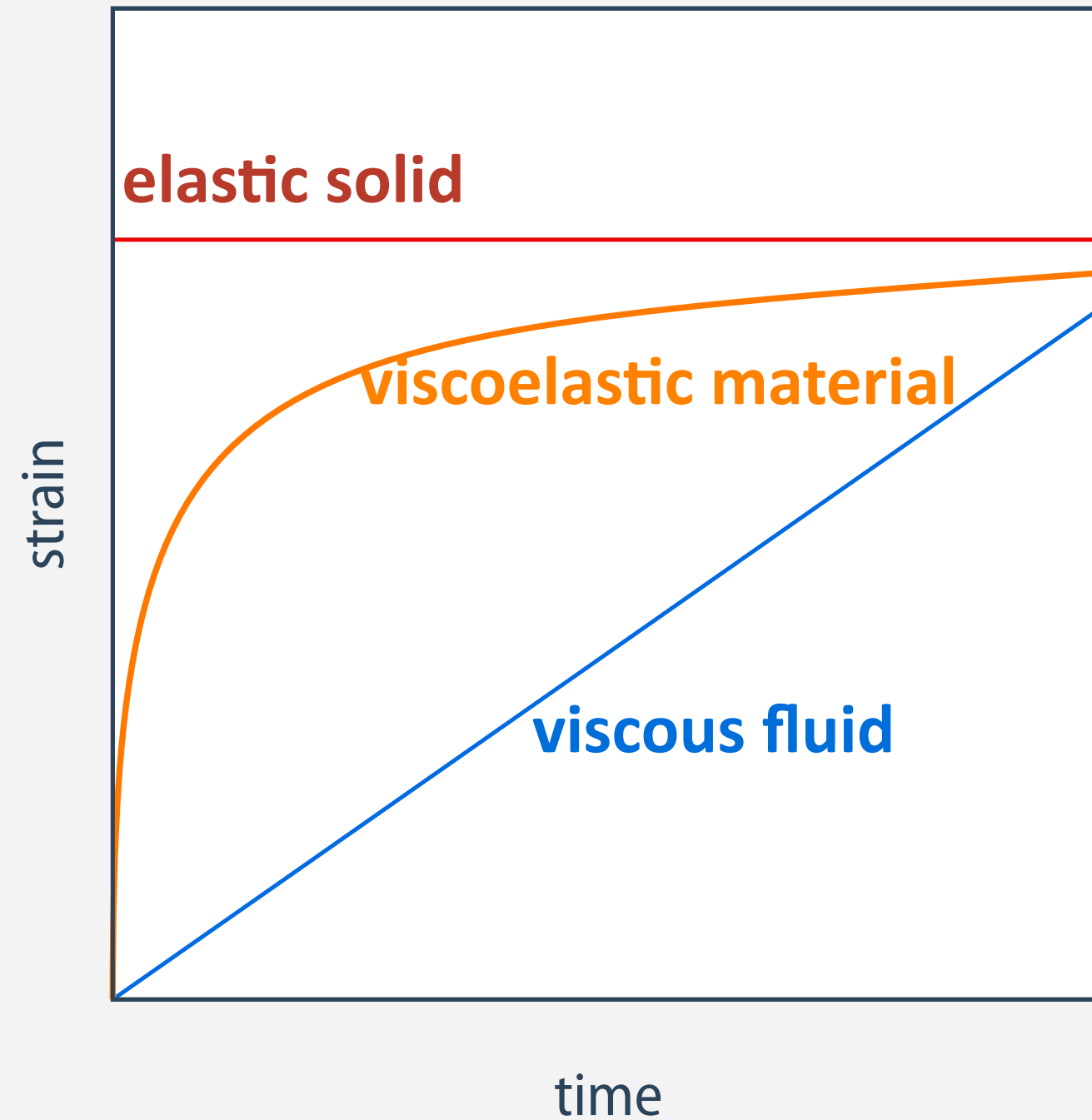

**relaxation**  
(constant strain)

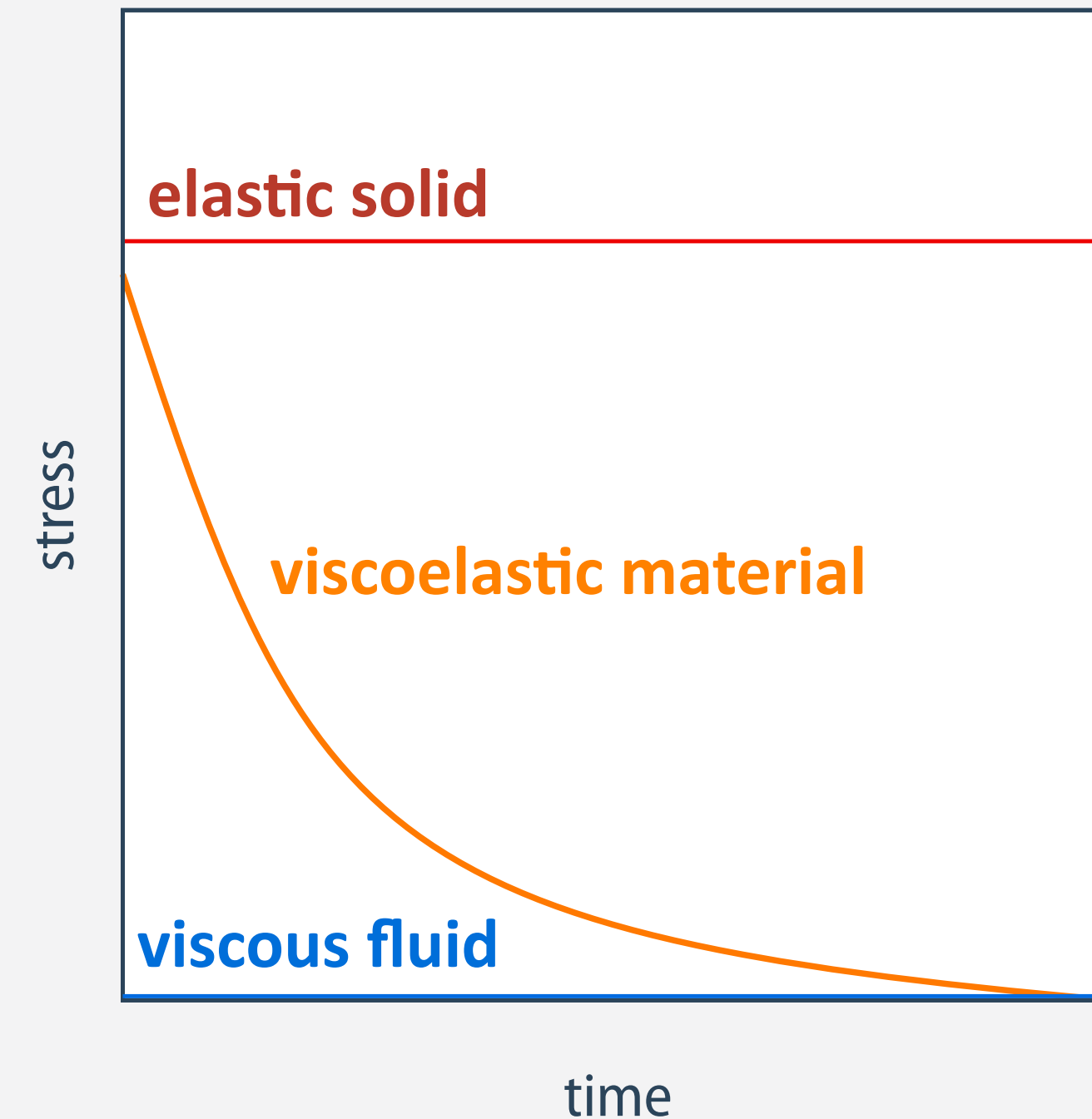

- **linear viscoelasticity: Hooke's & Newton's law** apply, modulus  $E = f(T, t)$  is stress-independent (valid for small deformations)
- **non-linear viscoelasticity: stress-dependent modulus**  $E = f(T, t, \sigma)$  (large deformations)

# Linear Viscoelasticity

# Time Dependence of Stress and Strain

- static creep and relaxation tests define viscoelastic functions for tension and shear

## Creep

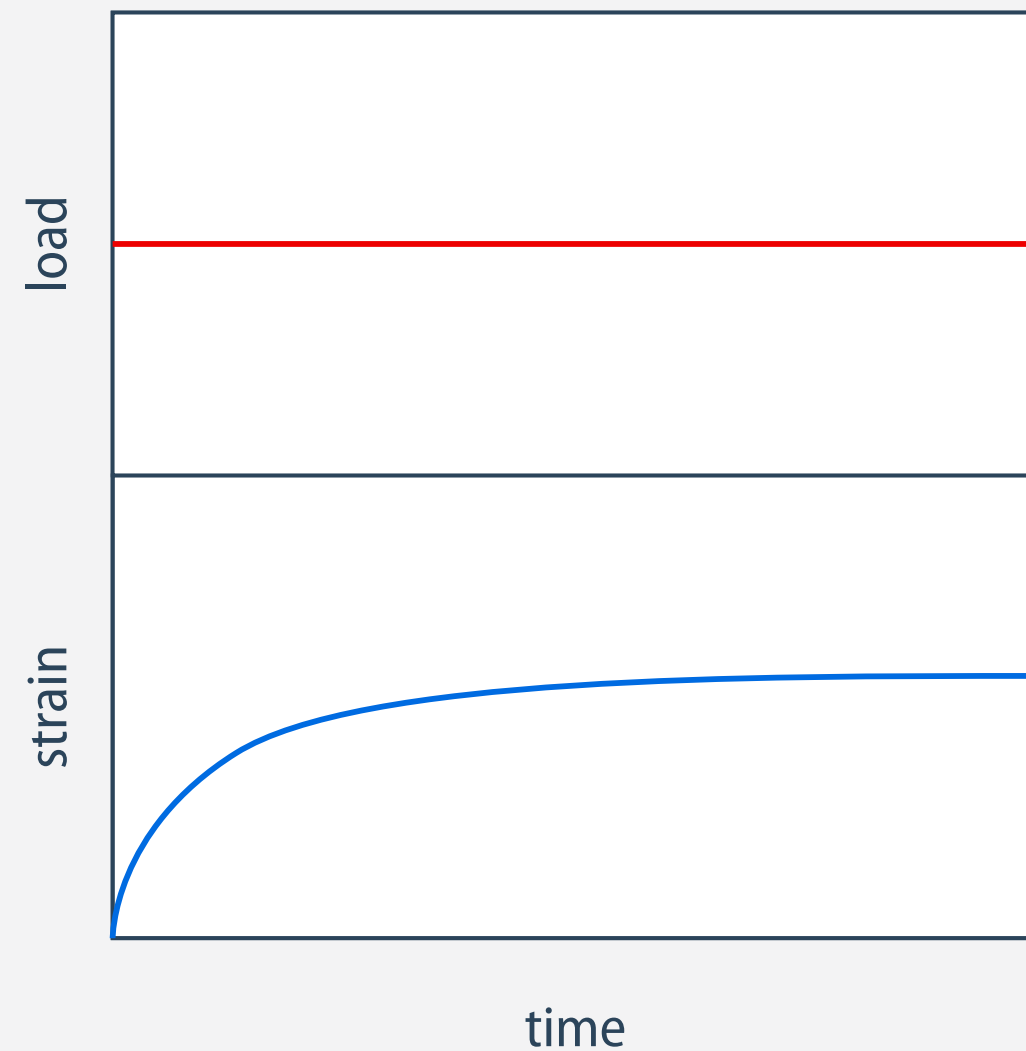

$$D(t) = \frac{\epsilon(t)}{\sigma_0} \quad J(t) = \frac{\gamma(t)}{\sigma_0}$$

## Relaxation

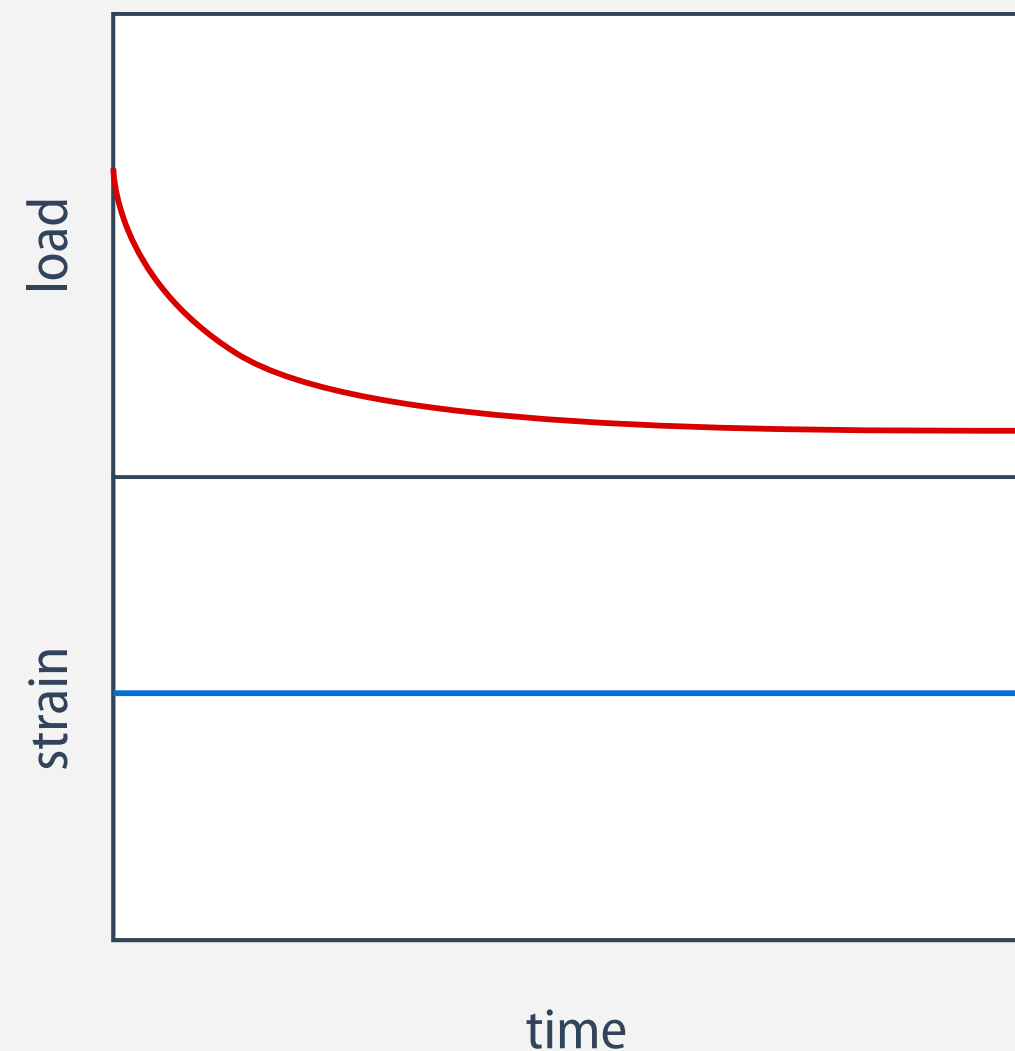

$$E(t) = \frac{\sigma(t)}{\epsilon_0} \quad G(t) = \frac{\sigma(t)}{\gamma_0}$$

## Constant Strain Rate

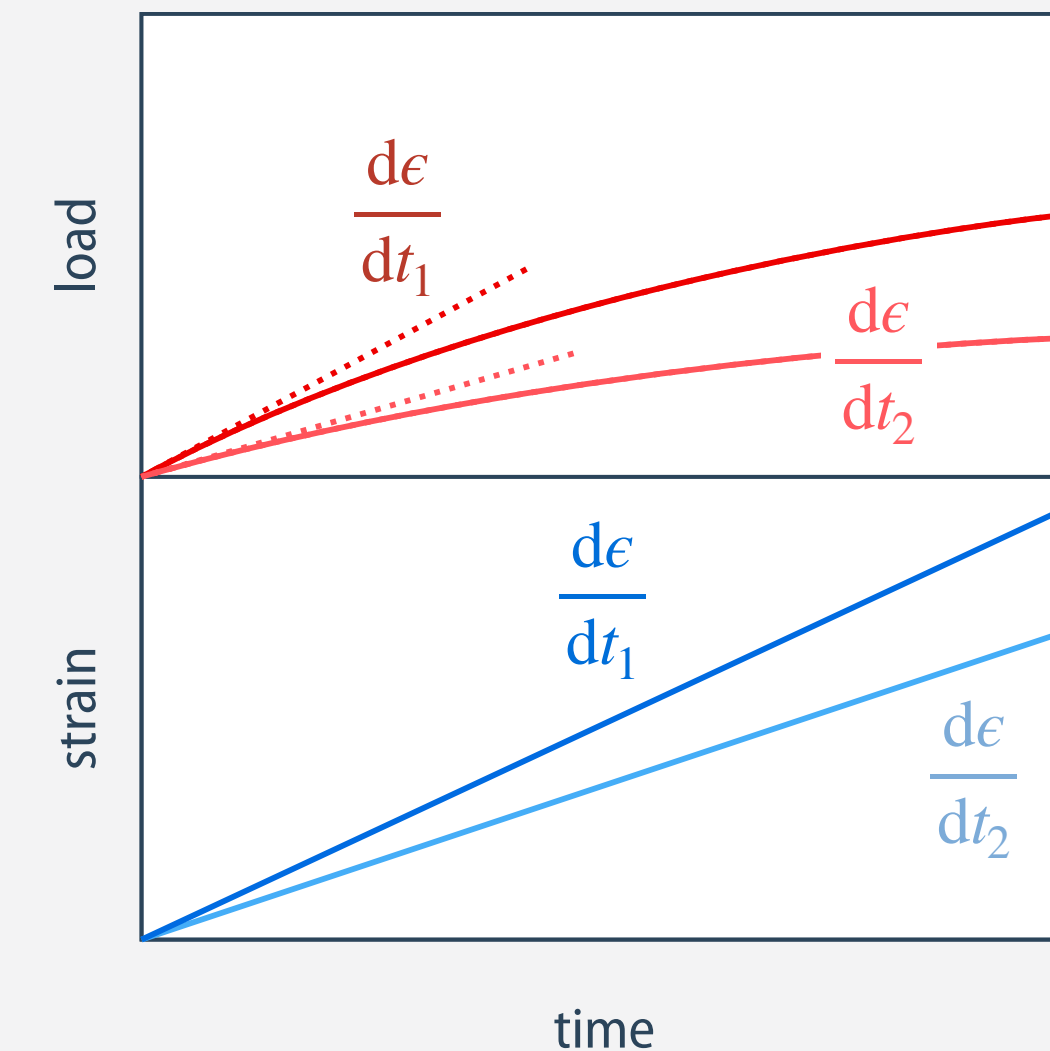

- $D(t)$  and  $J(t)$ : **compliances**,  $E(t)$  and  $G(t)$ : **moduli** (compliances and moduli are independent of each other)
- do not confuse with the time-independent Young's modulus ( $E = 1/D$  only for Hookean solids)

# Dynamic Mechanical Analysis

# Deformation under Shear

- small strain experiments are conveniently performed under shear

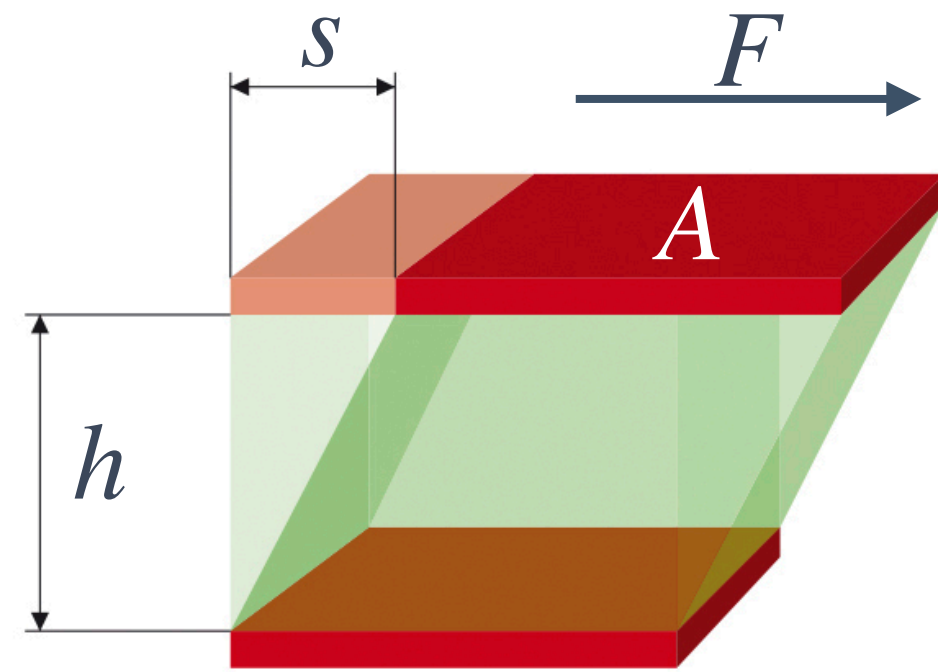

shear stress:  $\sigma = \frac{F}{A}$

shear strain:  $\gamma = \frac{s}{h}$

shear modulus:  $G = \frac{\sigma}{\gamma}$

material	shear modulus ( $G$ )
very soft gel structures (salad dressing)	5-10 Pa
soft gel structures (coatings, paints)	10-50 Pa
viscoelastic gels (dispersions, lotions,...)	50-5'000 Pa
<b>gummy bears</b>	10-500 kPa
<b>car tires (hard rubbers)</b>	10-100 MPa
<b>thermoplastic polymers</b>	0.1-2 GPa
ceramics, glass	15 - 35 GPa
aluminum	28 GPa
steel	80 GPa

- higher  $G$  indicates greater stiffness

# Dynamic Mechanical Measurements

- samples are subjected to oscillatory stress or strain (shear, tension, or bending)

## dynamic mechanical analysis (DMA)

shear or tensile deformation

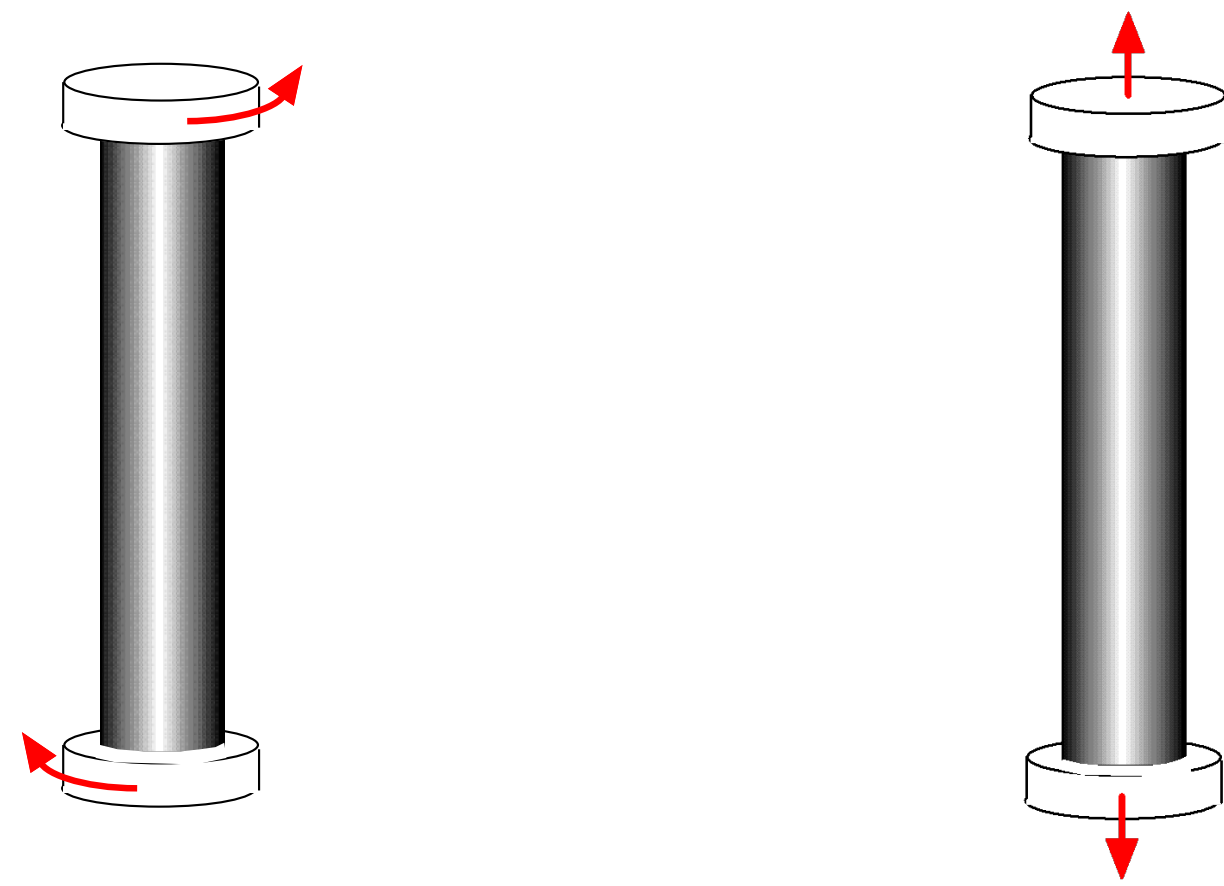

$$\gamma(t) = \gamma_0 \sin(\omega t)$$

$$\epsilon(t) = \epsilon_0 \sin(\omega t)$$

typical for solid samples

## rheometry

usually shear deformation

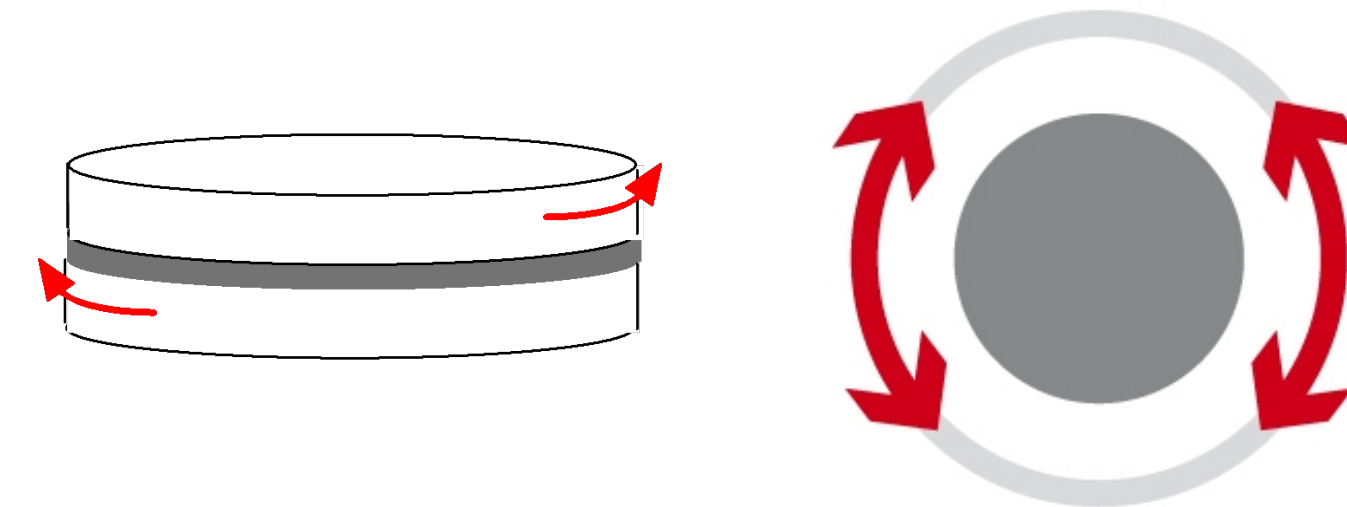

$$\gamma(t) = \gamma_0 \sin(\omega t)$$

typical for liquids

- stress is measured as a function of  $T$  (at constant  $\omega$ ) or of  $\omega$  (at constant  $T$ )

# Periodic Deformation

- oscillatory tests probe both solid-like and liquid-like responses

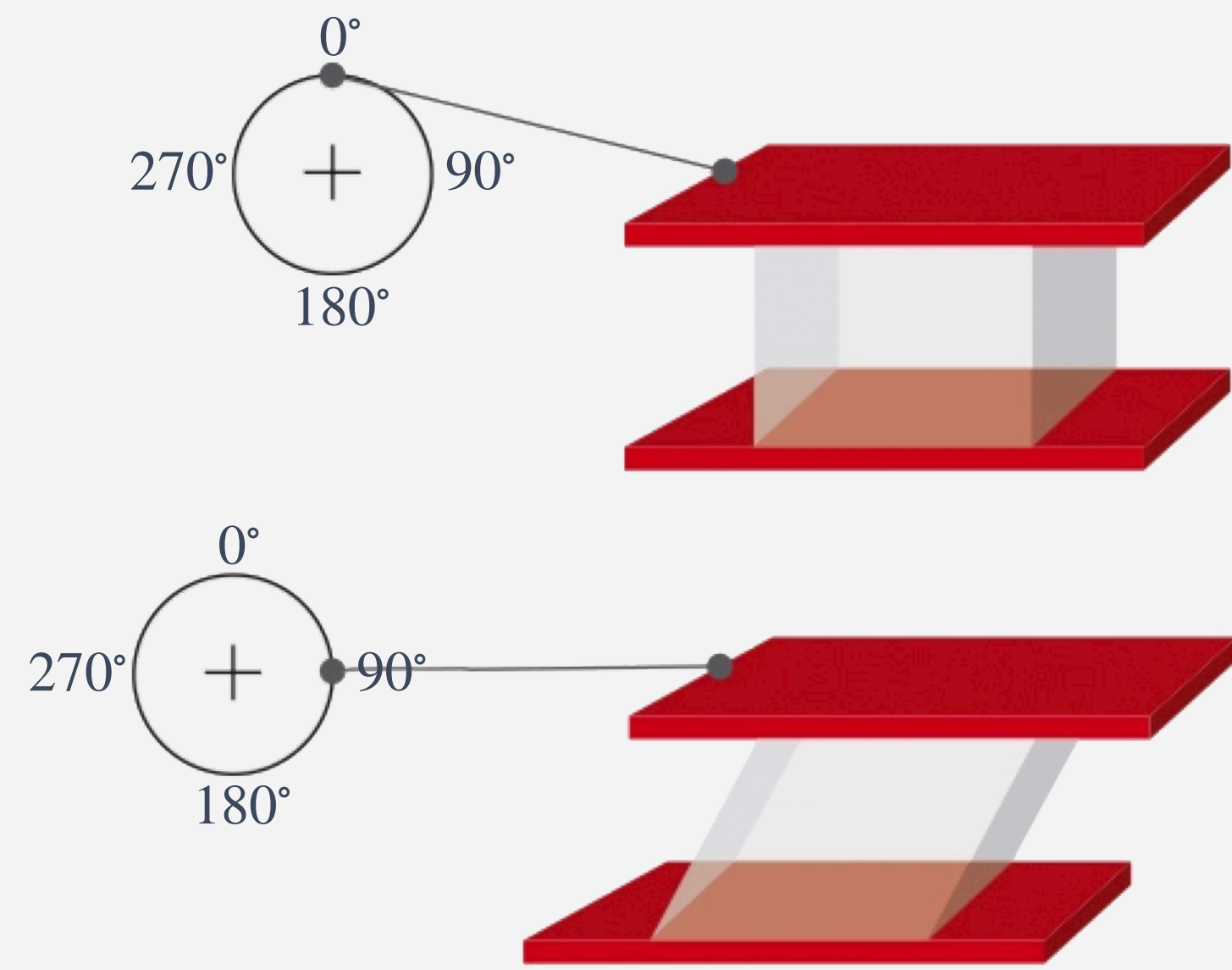

**Hookean solid**

$$\delta = 0^\circ$$

**viscoelastic material**

$$0^\circ < |\delta| < 90^\circ$$

**Newtonian fluid**

$$\delta = 90^\circ$$

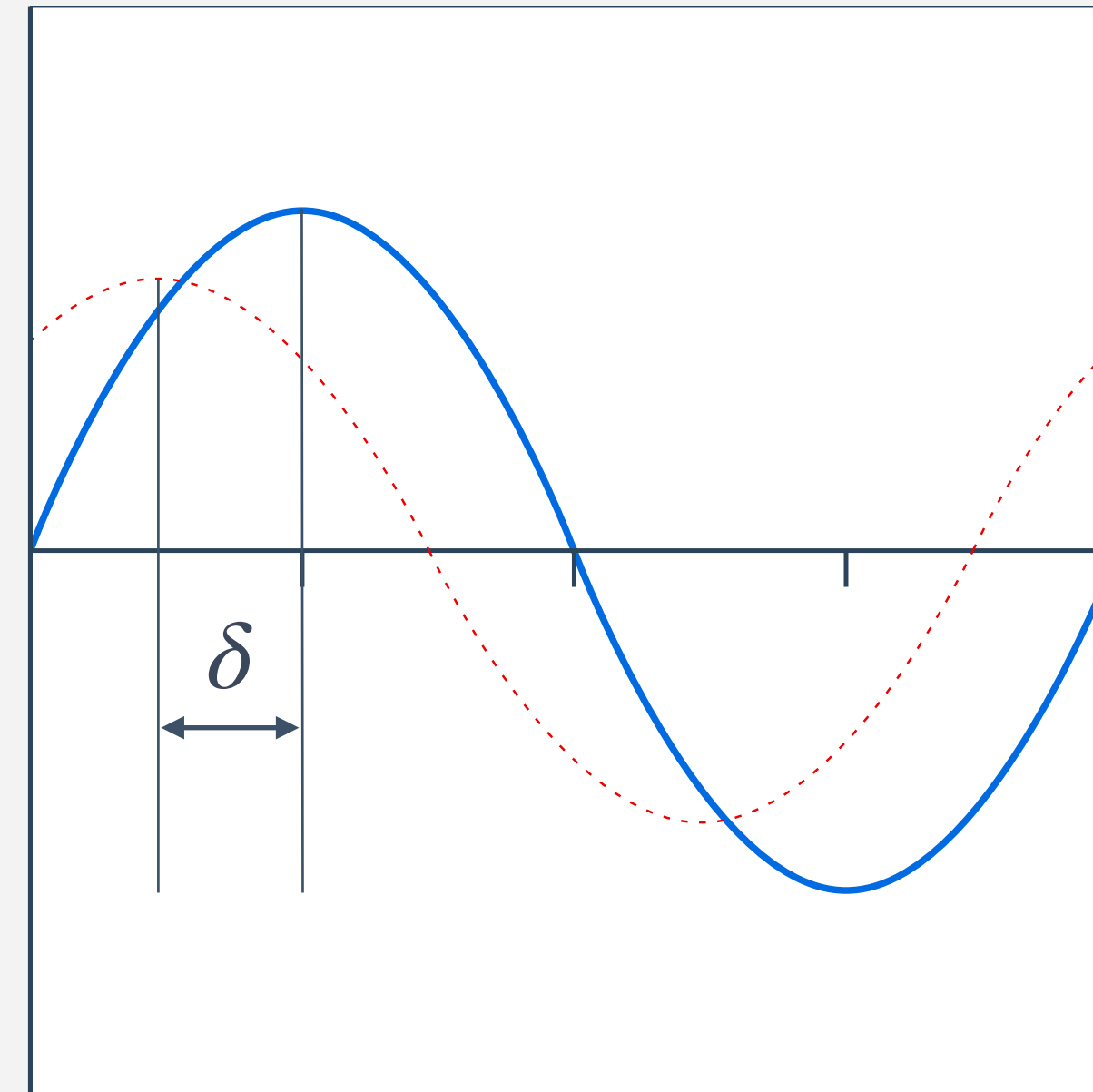

$$\sigma(t) = G\gamma = \sigma_0 \sin(\omega t + \delta)$$

$$\gamma(t) = \gamma_0 \sin(\omega t)$$

- the deformation is typically applied as a sine wave

# Storage Modulus, Loss Modulus & Loss Factor

$$\gamma(t) = \gamma_0 \sin(\omega t)$$

$$\sigma(t) = \sigma_0 \sin(\omega t + \delta) = \sigma_0(\sin(\omega t)\cos(\delta) + \cos(\omega t)\sin(\delta))$$

$$\frac{\sigma(t)}{\gamma_0} = \frac{\sigma_0}{\gamma_0}(\sin(\omega t)\cos(\delta)) + \frac{\sigma_0}{\gamma_0}(\cos(\omega t)\sin(\delta)) \equiv G' \sin(\omega t) + G'' \cos(\omega t)$$

**storage modulus:**

$$G' = \frac{\sigma_0}{\gamma_0} \cos(\delta)$$

**loss modulus:**

$$G'' = \frac{\sigma_0}{\gamma_0} \sin(\delta)$$

**loss factor:**

$$\tan(\delta) = \frac{G''}{G'}$$

- **storage modulus**  $G'$ : elastic portion of the viscoelastic behavior (stored deformation energy)
- **loss modulus**  $G''$ : viscous portion of the viscoelastic behavior (dissipated energy during viscous flow)
- **loss factor** or **damping factor**  $\tan(\delta)$ : ratio between  $G''$  and  $G'$  (maxima often indicate transitions)

# Complex Moduli

- the entire viscoelastic response is described by the complex shear modulus  $G^*$

$$\begin{aligned} G^* &= \frac{\sigma^*}{\gamma^*} = \frac{\sigma_0 e^{i(\omega t + \delta)}}{\gamma_0 e^{i\omega t}} \\ &= \frac{\sigma_0 e^{i\delta}}{\gamma_0} = \frac{\sigma_0 (\cos(\delta) + i \sin(\delta))}{\gamma_0} \\ &= G' + iG'' \end{aligned}$$

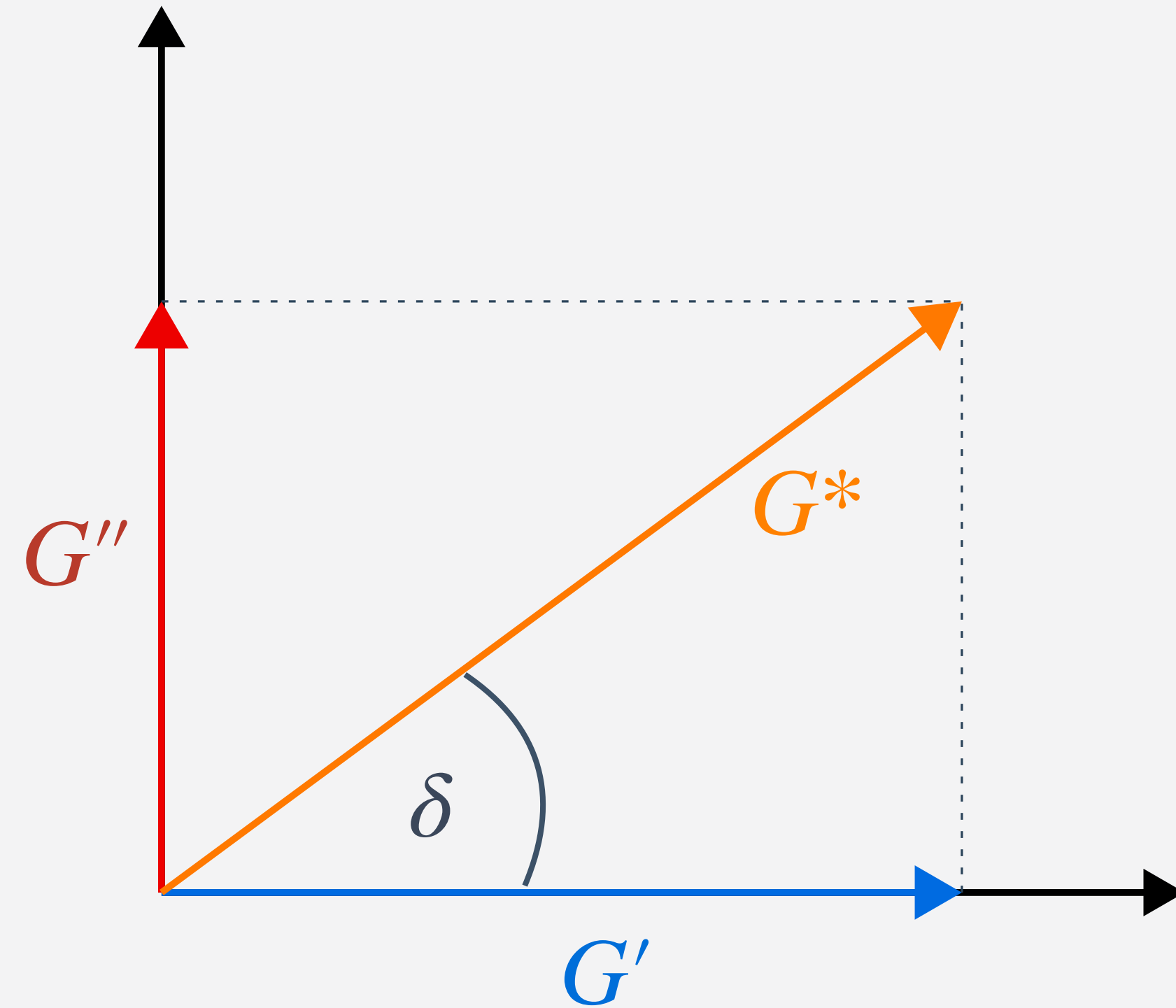

viscoelastic solids:  $G' > G''$

viscoelastic liquids:  $G'' > G'$

- $G'$  and  $G''$  represent the real and imaginary components of the total response

# Simple Mechanical Models

# Elastic Springs and Dashpots

**elastic solids**  
reversible deformation

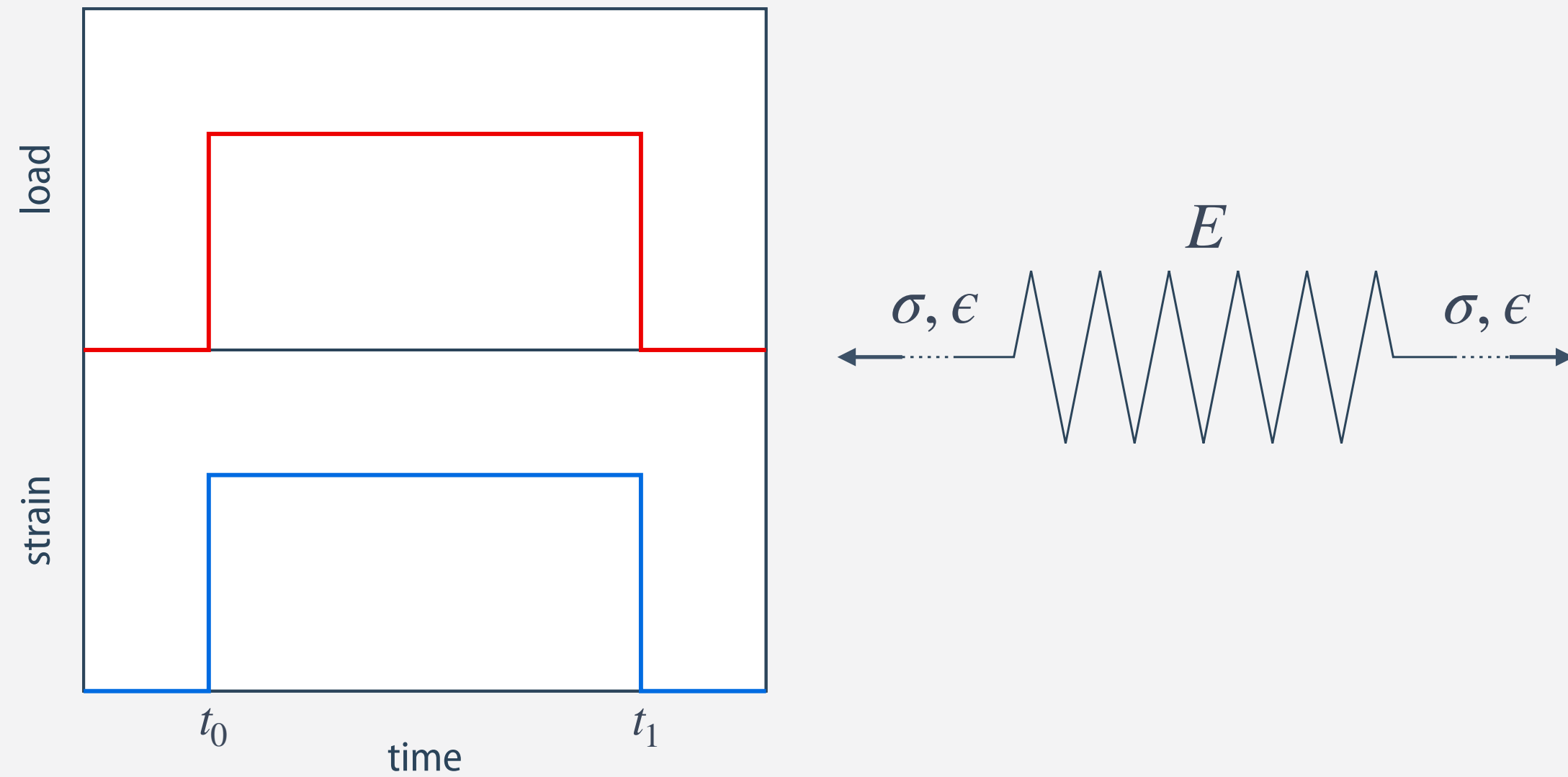

**Hooke's law:**

$$\sigma = E\epsilon$$

**viscous liquids**  
irreversible deformation

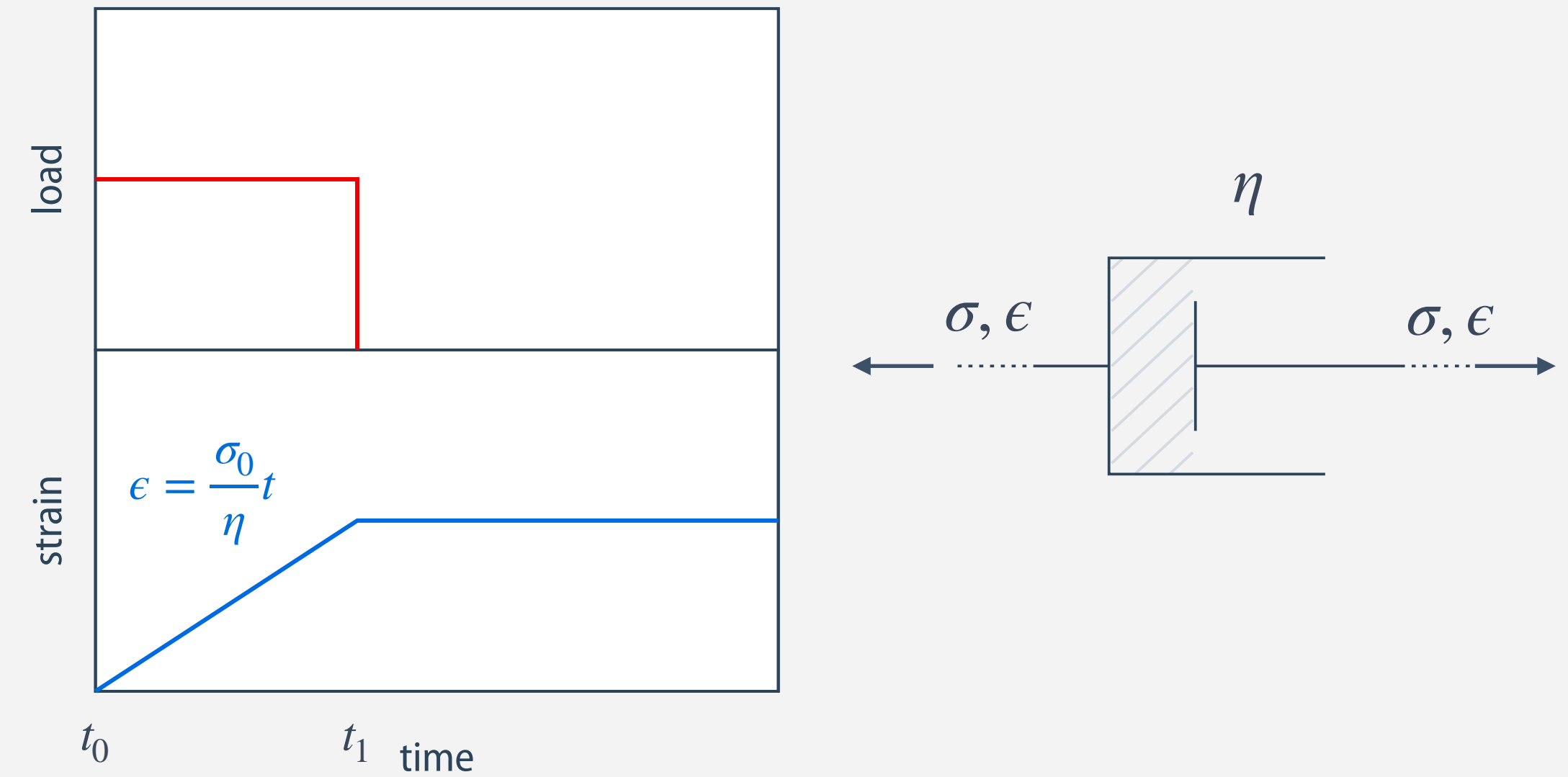

**Newton's law:**

$$\dot{\epsilon} = \frac{\sigma}{\eta}$$

- mechanical analogues for elasticity (spring) and viscous flow (dashpot)

# Simple Viscoelastic Models: Linear Combinations of Dashpots & Elastic Springs

elastic solids

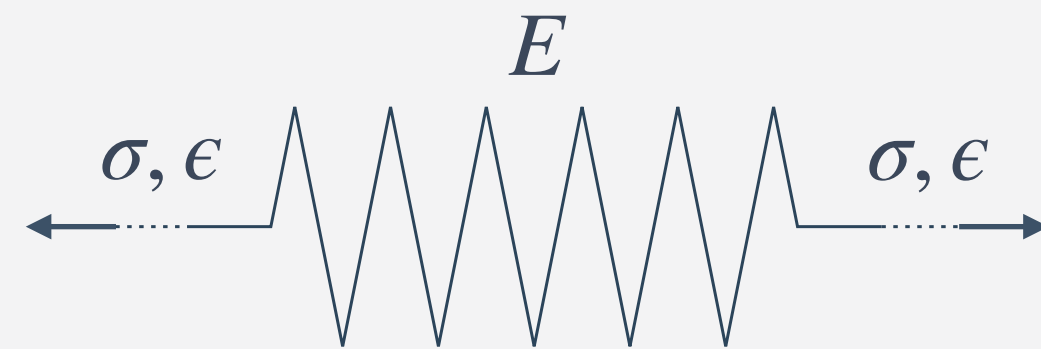

Hooke's law:

$$\sigma = E\epsilon$$

viscous liquids

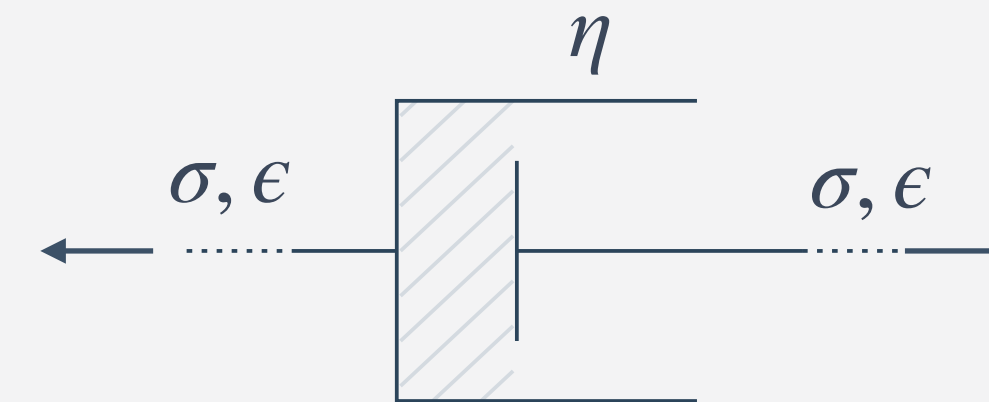

Newton's law:

$$\dot{\epsilon} = \frac{\sigma}{\eta}$$

Maxwell model

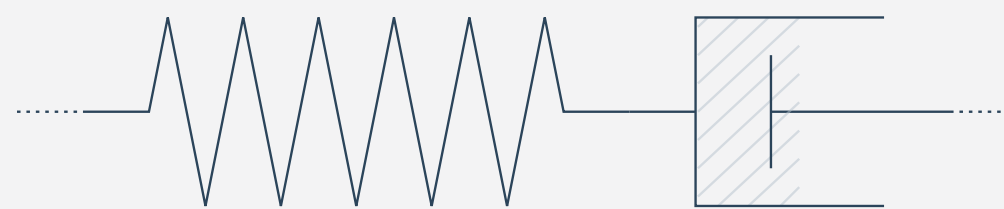

$$\sigma = \sigma_1 = \sigma_2$$

$$\epsilon = \epsilon_1 + \epsilon_2$$

Voigt model

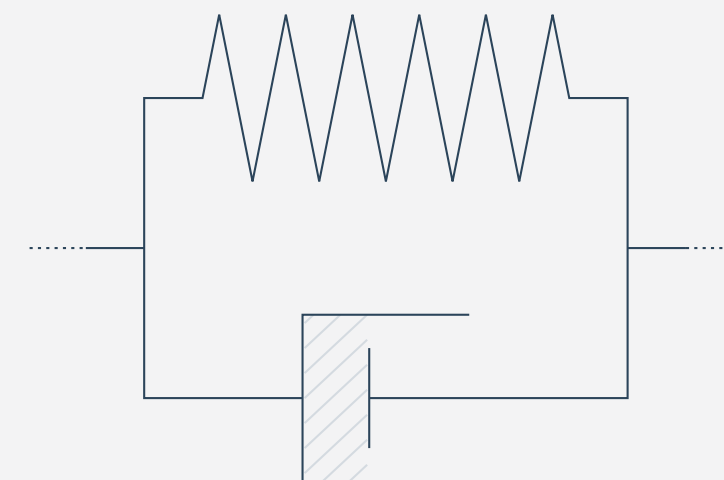

$$\sigma = \sigma_1 + \sigma_2$$

$$\epsilon = \epsilon_1 = \epsilon_2$$

Zener models (standard linear solid)

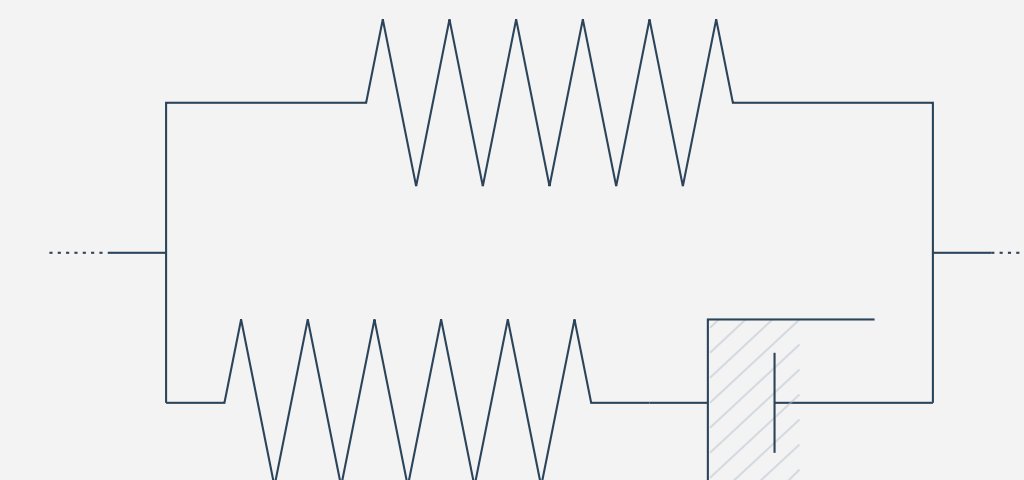
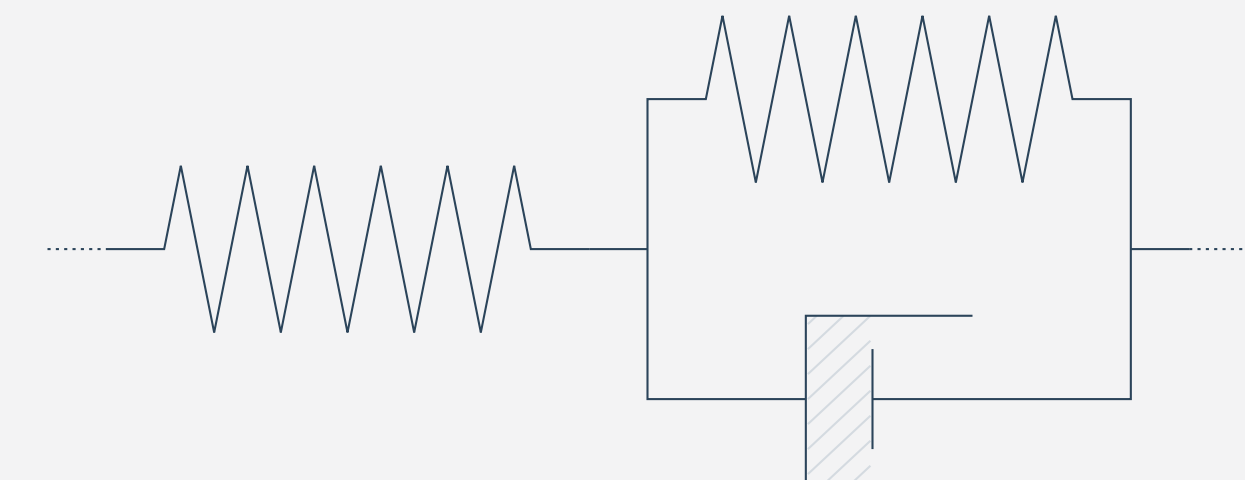

# Boltzmann's Superposition Principle

- the state of stress or strain depends on the entire loading history:

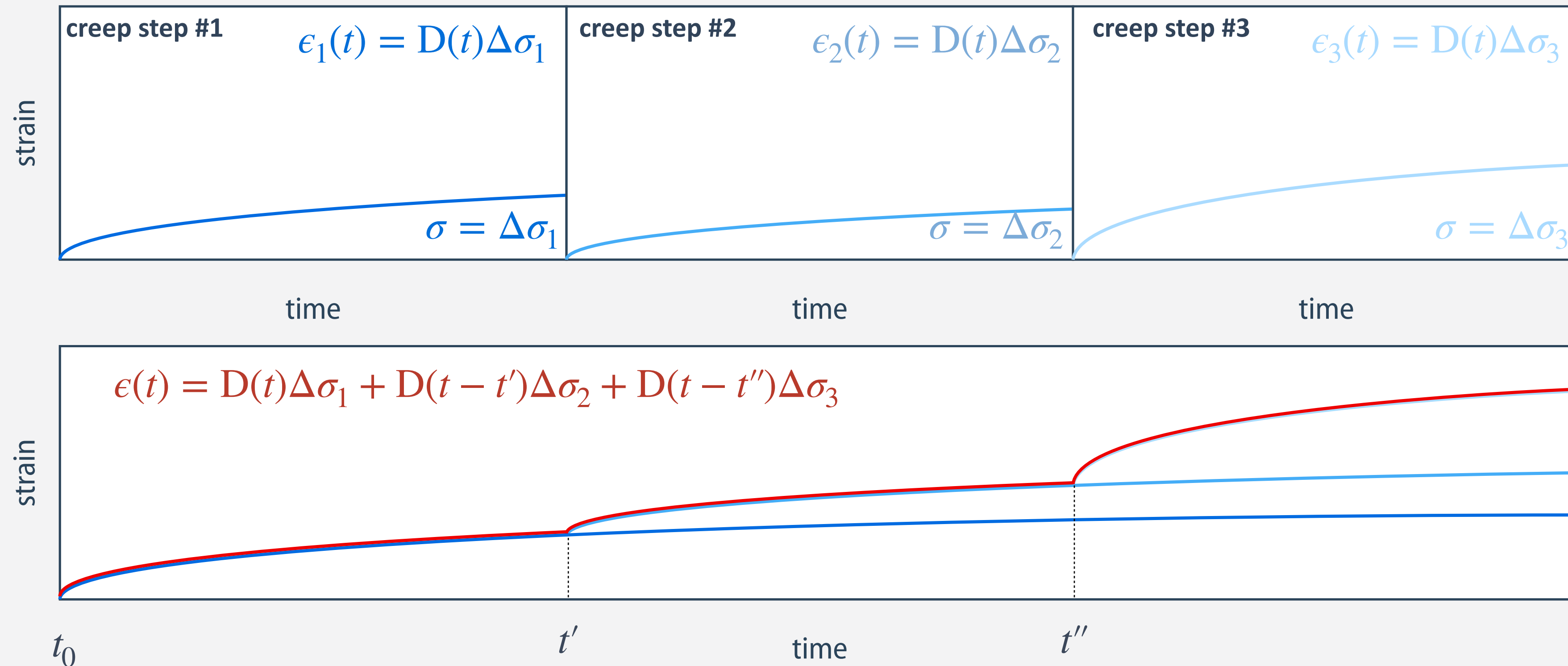

- generalized discrete form:

$$\epsilon(t) = \sum_{n=0} D(t - t_n)\Delta\sigma_n$$

- the material “remembers” all previous stresses or or deformations

# Continuous Boltzmann Superposition

- in the continuous limit: Boltzmann superposition integral

creep experiment:

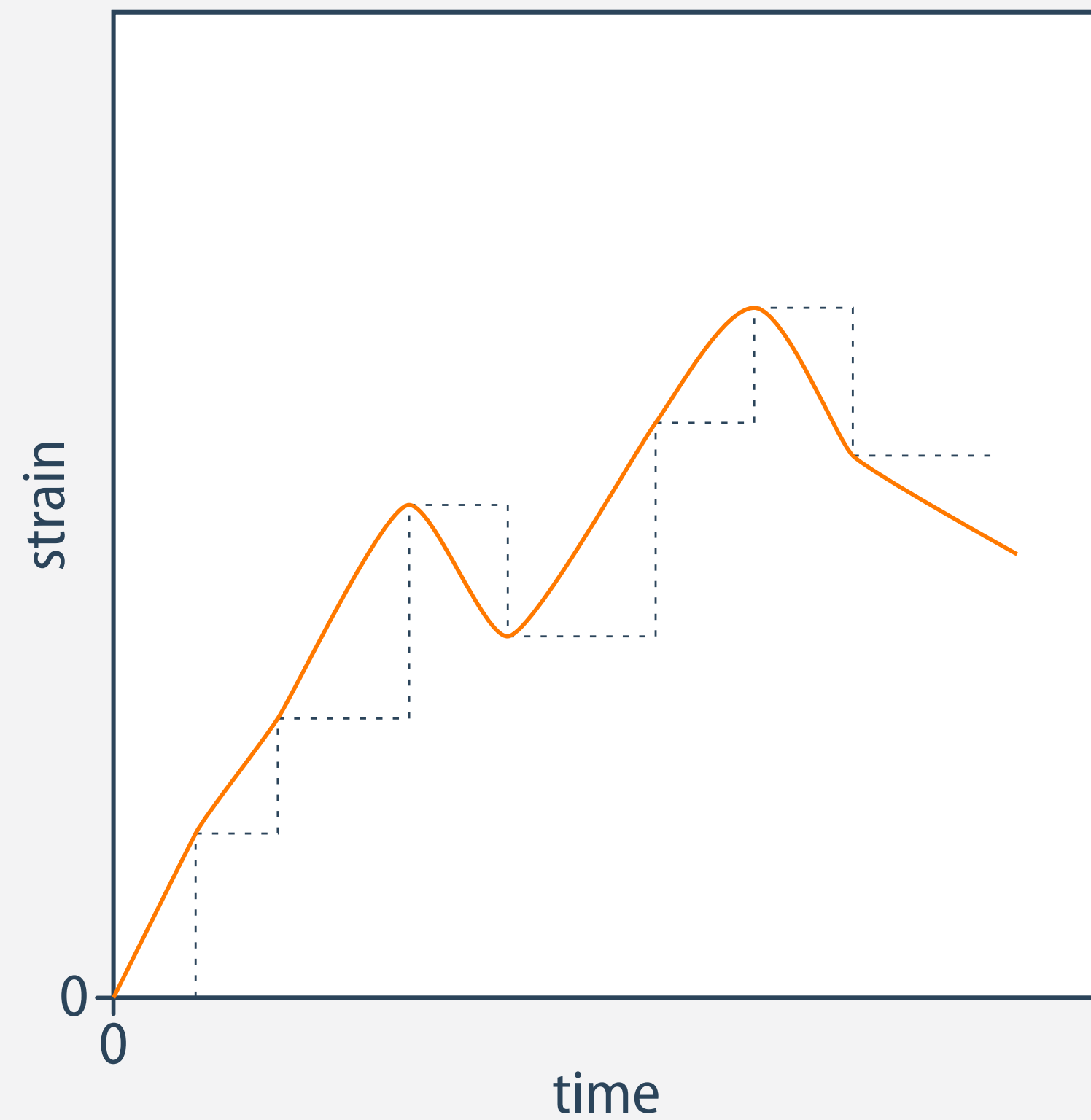

$$\epsilon(t) = \int_{-\infty}^t D(t - t') \frac{d\sigma}{dt'} dt'$$

for stress relaxation

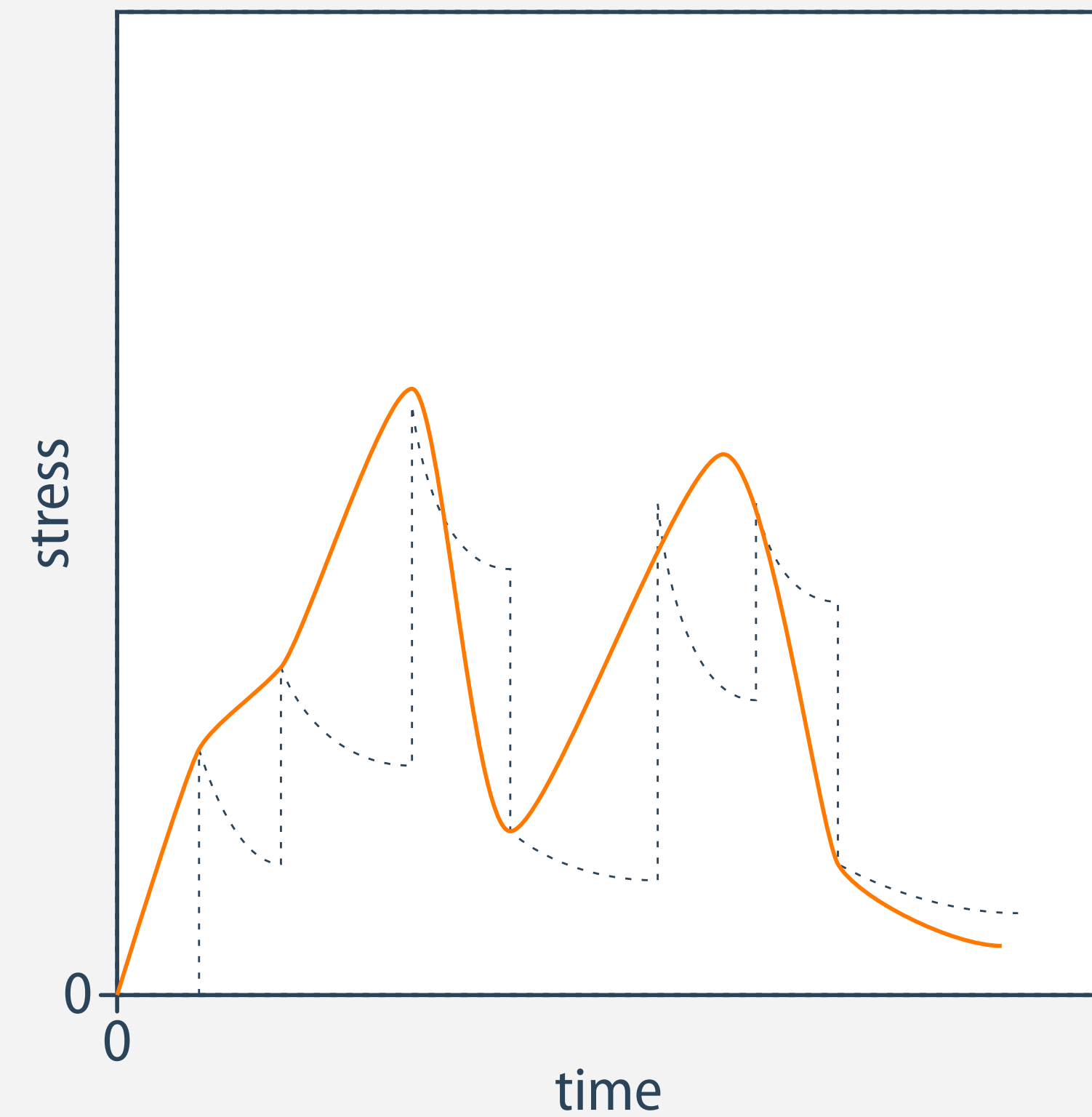

$$\sigma(t) = \int_{-\infty}^t E(t - t') \frac{d\epsilon}{dt'} dt'$$

# Maxwell Model

- series combination of one spring and one dashpot:



$$\epsilon = \epsilon_1 + \epsilon_2 = \epsilon_0 = \text{constant}$$

(for a relaxation experiment)

$$\frac{d\epsilon}{dt} = \frac{d\epsilon_1}{dt} + \frac{d\epsilon_2}{dt} = \frac{1}{E} \frac{d\sigma}{dt} + \frac{\sigma}{\eta} = 0$$

$$\frac{d\sigma}{\sigma} = -\frac{E}{\eta} dt \quad \rightarrow \quad [\ln(\sigma)]_{\sigma_0}^{\sigma} = -\frac{E}{\eta} [t']_0^t$$

$$\sigma = \sigma_0 e^{(-t/\tau)} \quad \text{with} \quad \tau = \frac{\eta}{E}$$

$$E(t) = \frac{\sigma}{\epsilon_0} = \frac{\sigma_0}{\epsilon_0} e^{(-t/\tau)} = E e^{(-t/\tau)}$$

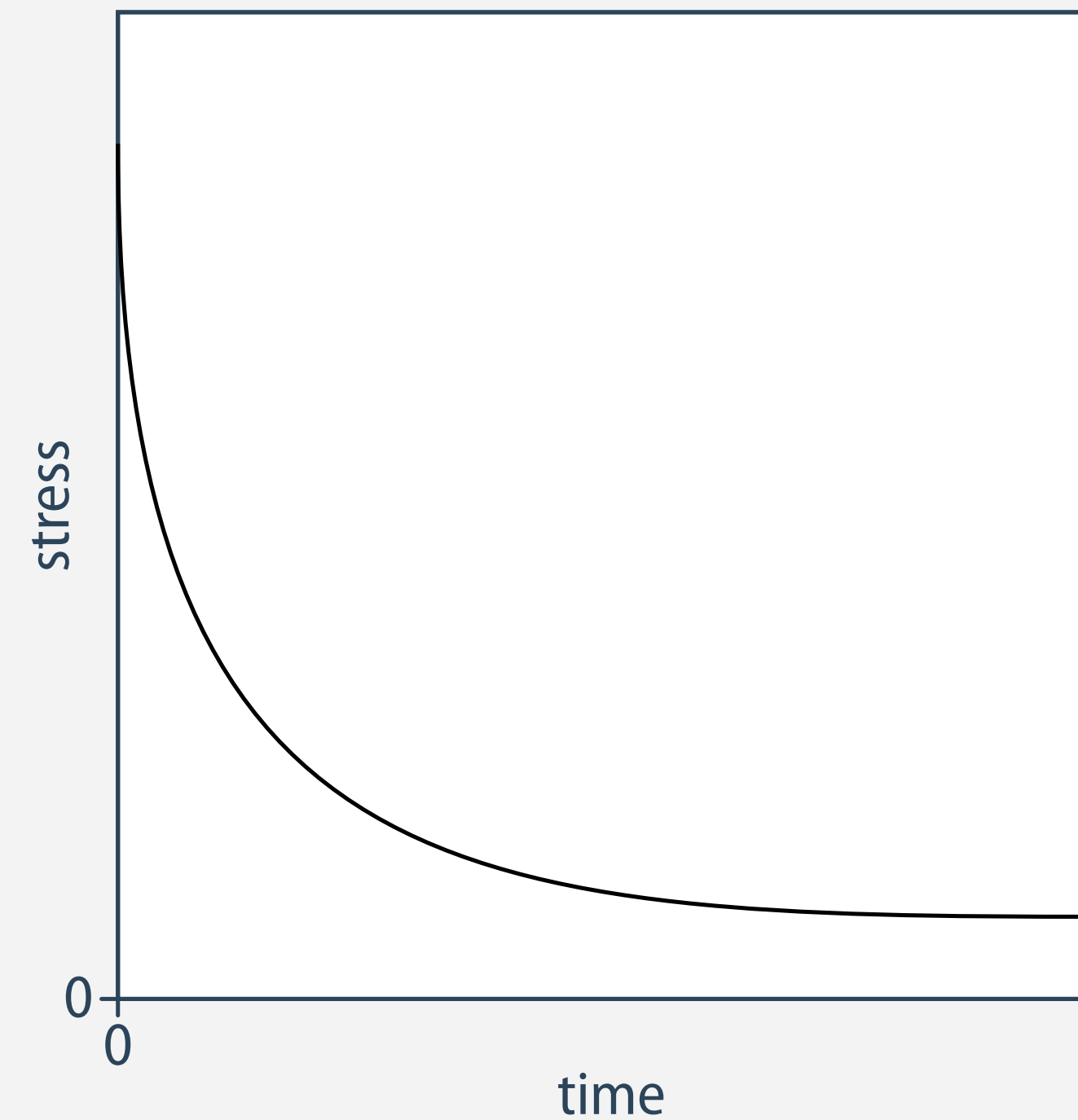

- describes stress relaxation, characterised by a single relaxation time  $\tau$

# Maxwell Model under Dynamic Deformation

- for sinusoidal strain:  $\epsilon^* = \epsilon_0 e^{i\omega t}$        $\frac{d\epsilon^*}{dt} = i\omega\epsilon_0 e^{i\omega t}$

- for the stress under continuous deformation follows using the Boltzmann principle:

$$\begin{aligned}\sigma^* &= \int_{-\infty}^t E(t-t') \frac{d\epsilon^*}{dt'} dt' = \int_{-\infty}^t E e^{-\frac{t-t'}{\tau}} \epsilon_0 i\omega e^{i\omega t'} dt' \\ &= \frac{Ei\omega\epsilon_0}{\frac{1}{\tau} + i\omega} \left[ e^{(-\frac{t-t'}{\tau} + i\omega t')} \right]_{-\infty}^t = \frac{Ei\omega\epsilon_0}{\frac{1}{\tau} + i\omega} e^{i\omega t} = \frac{Ei\omega\epsilon_0(\frac{1}{\tau} - i\omega)}{\frac{1}{\tau^2} + \omega^2} e^{i\omega t} = \frac{Ei\epsilon_0(\omega\tau - i(\omega\tau)^2)}{1 + (\omega\tau)^2} e^{i\omega t}\end{aligned}$$

- the complex modulus and loss factor are then given by:

$$E^* = \frac{\sigma^*}{\epsilon^*} = \frac{Ei(\omega\tau - i(\omega\tau)^2)}{1 + (\omega\tau)^2} = \frac{E(\omega\tau)^2}{1 + (\omega\tau)^2} + \frac{iE\omega\tau}{1 + (\omega\tau)^2} = E' + iE'' \qquad \tan(\delta) = \frac{E''}{E'} = \frac{1}{\omega\tau}$$

# Modeling Rheology Curves

- constructing rheology curves:

$$= E' + iE'' = \frac{E(\omega\tau)^2}{1 + (\omega\tau)^2} + \frac{iE\omega\tau}{1 + (\omega\tau)^2}$$

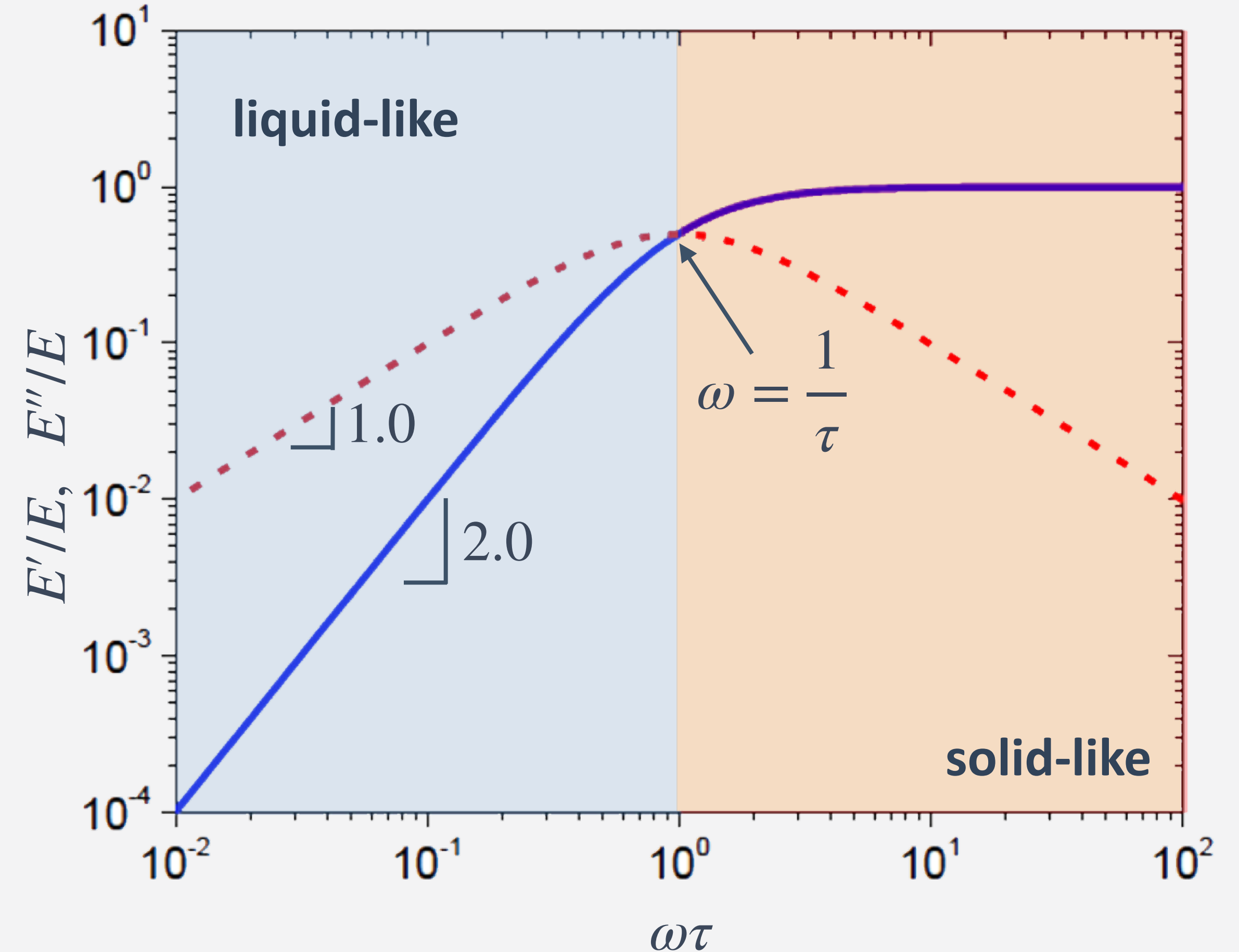

- relaxation time  $\tau$  marks the transition from liquid-like to solid-like behavior
- $E'$  and  $E''$  show universal frequency dependence in the terminal regime ( $\omega \ll \tau$ )

# Experimental Validation

- Maxwell behavior is often encountered in temporary networks from small molecules (due to the formation of hydrogen-bonds, for example) with a single relaxation time  $\tau$

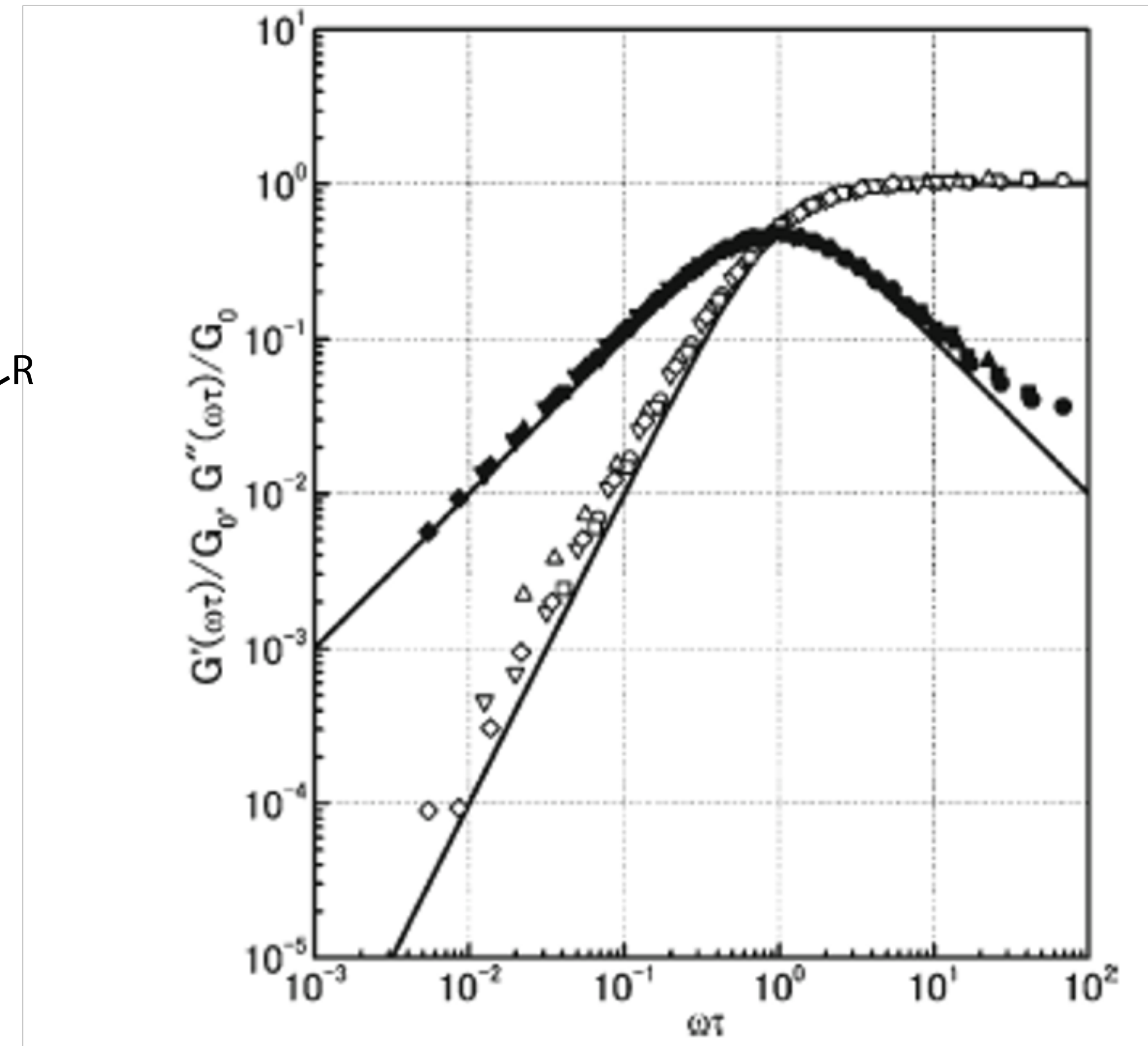
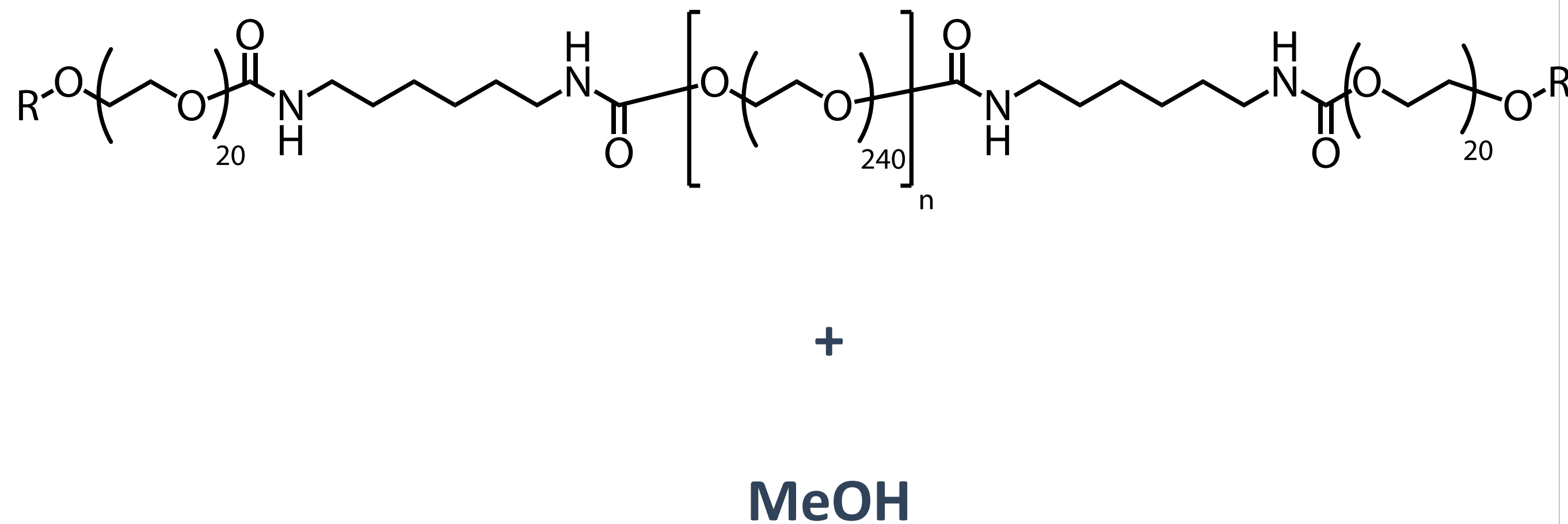

# Limitations

Maxwell behavior

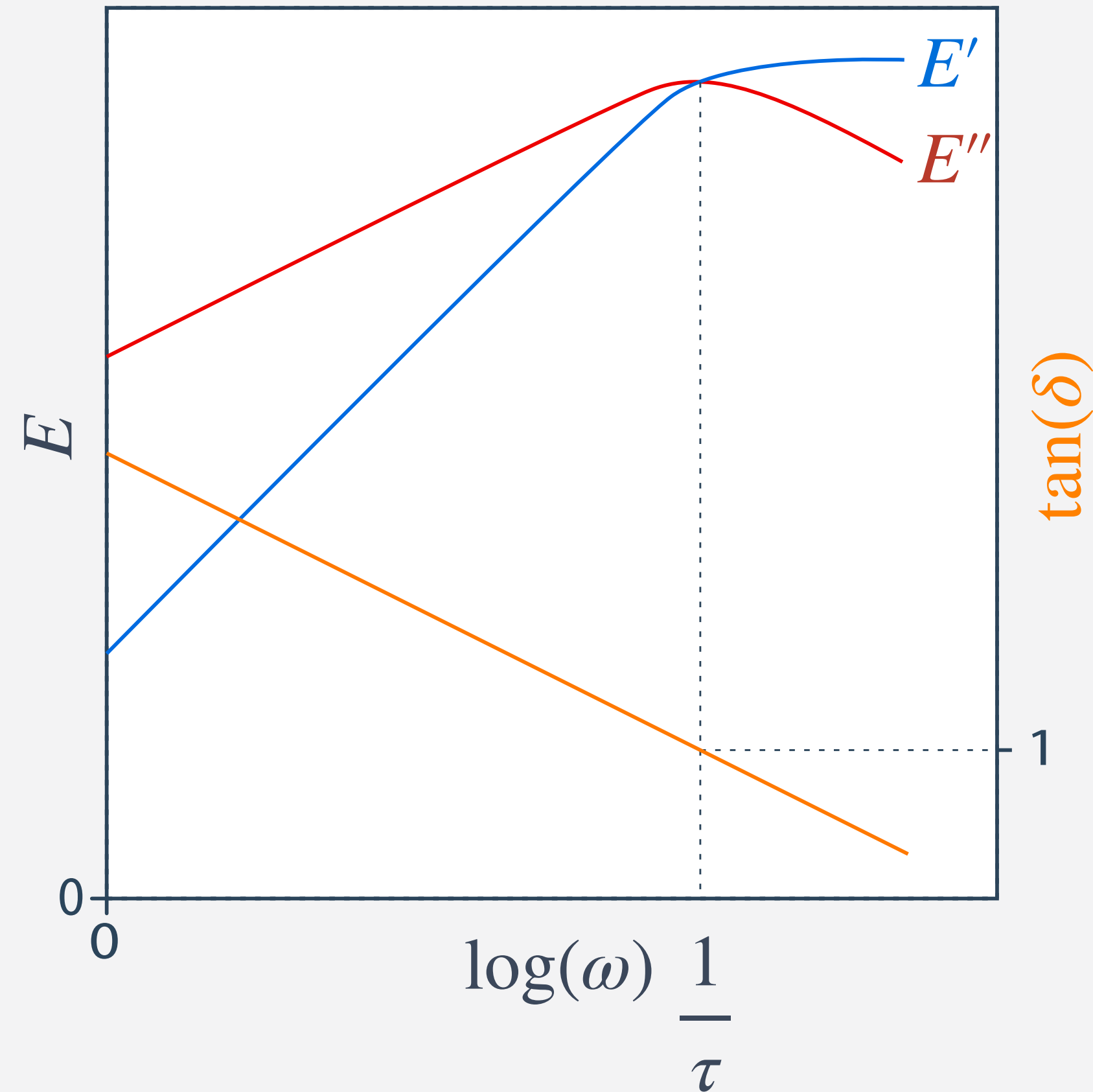

real polymers

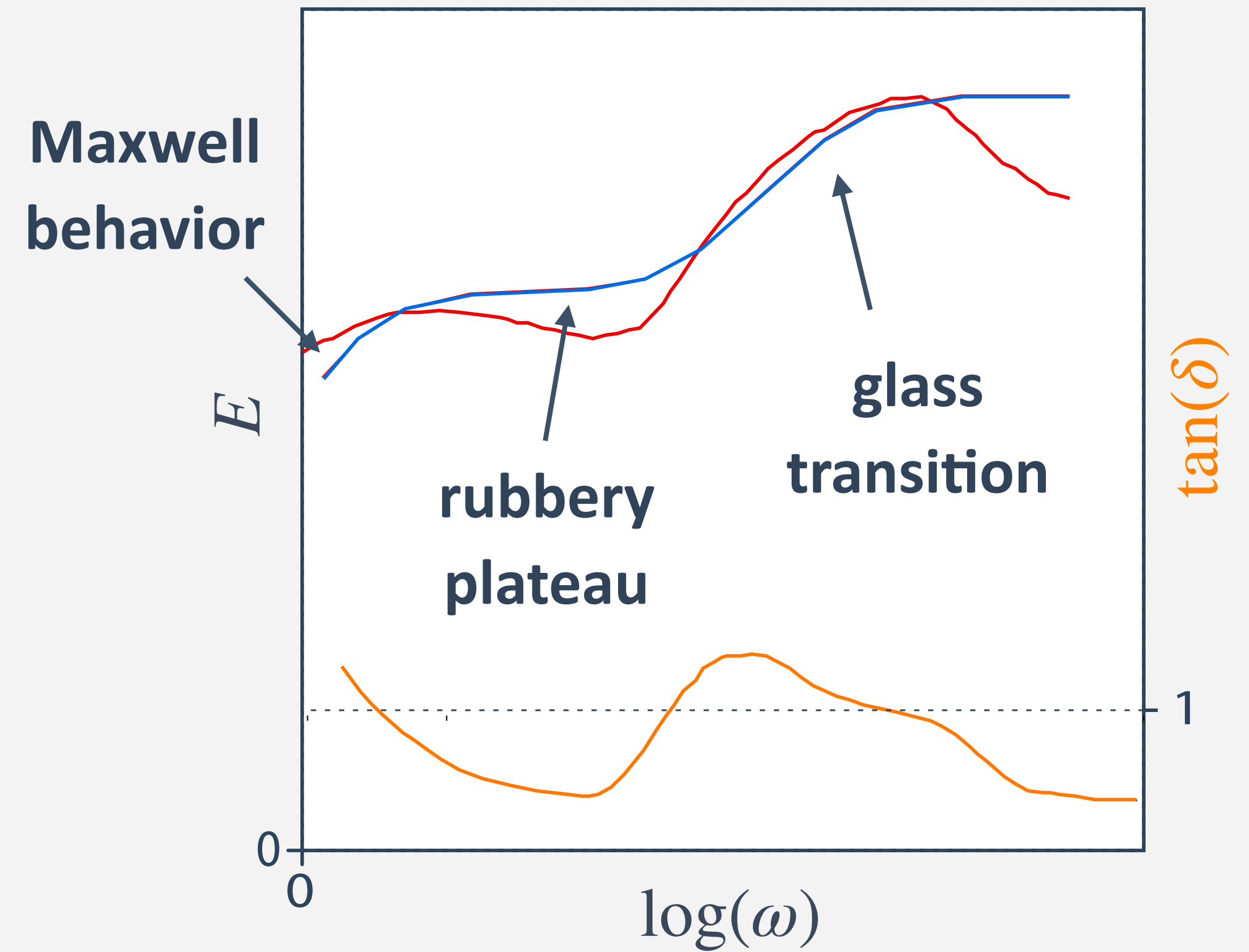

- the Maxwell model is oversimplified for real polymers
- the Voigt model (parallel arrangement of spring and dashpot) also fails (see Exercise)

# Maxwell vs. Voigt Model

creep experiment  
(constant stress  $\sigma_0$ )

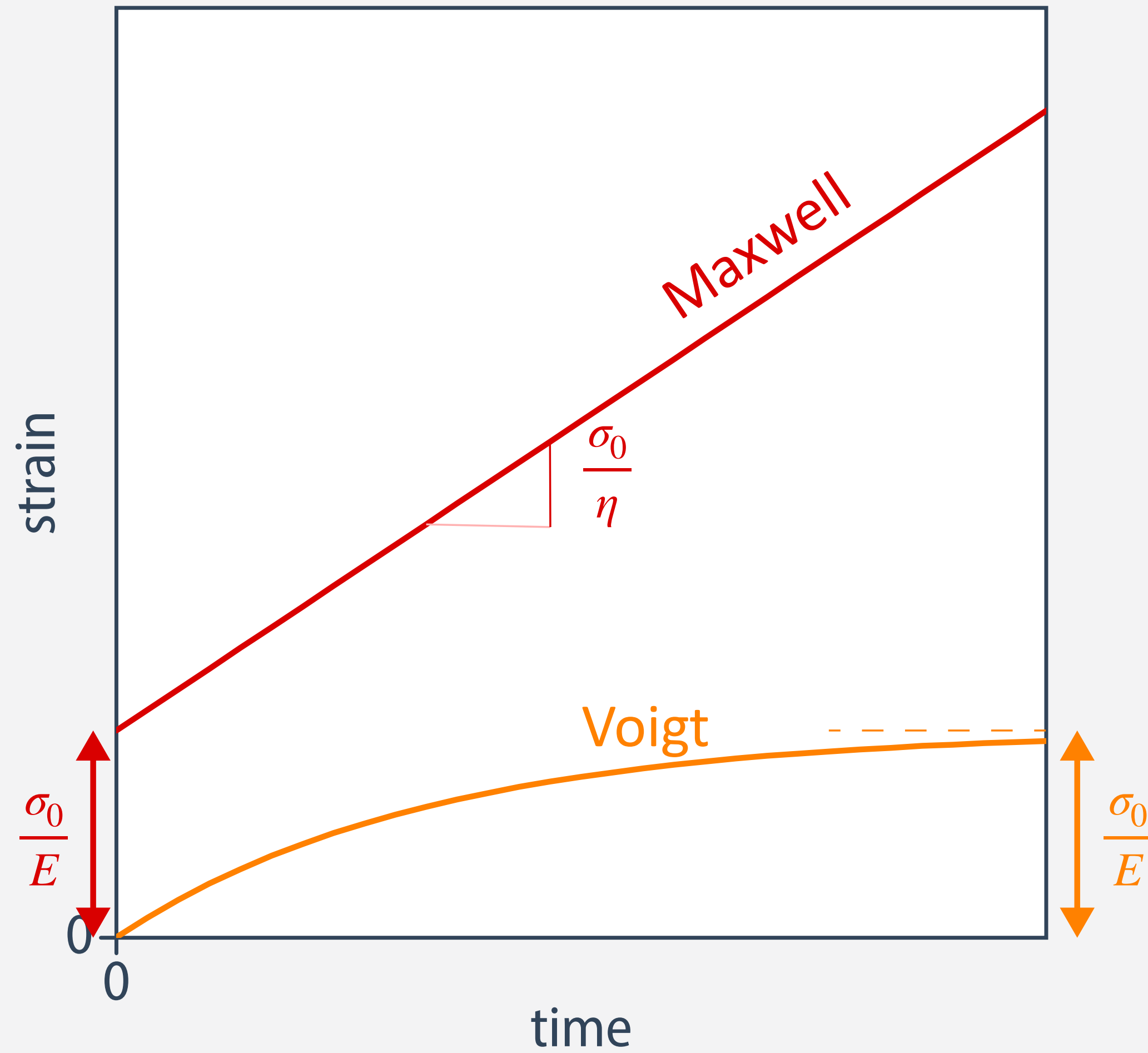

relaxation experiment  
(constant strain  $\epsilon_0$ )

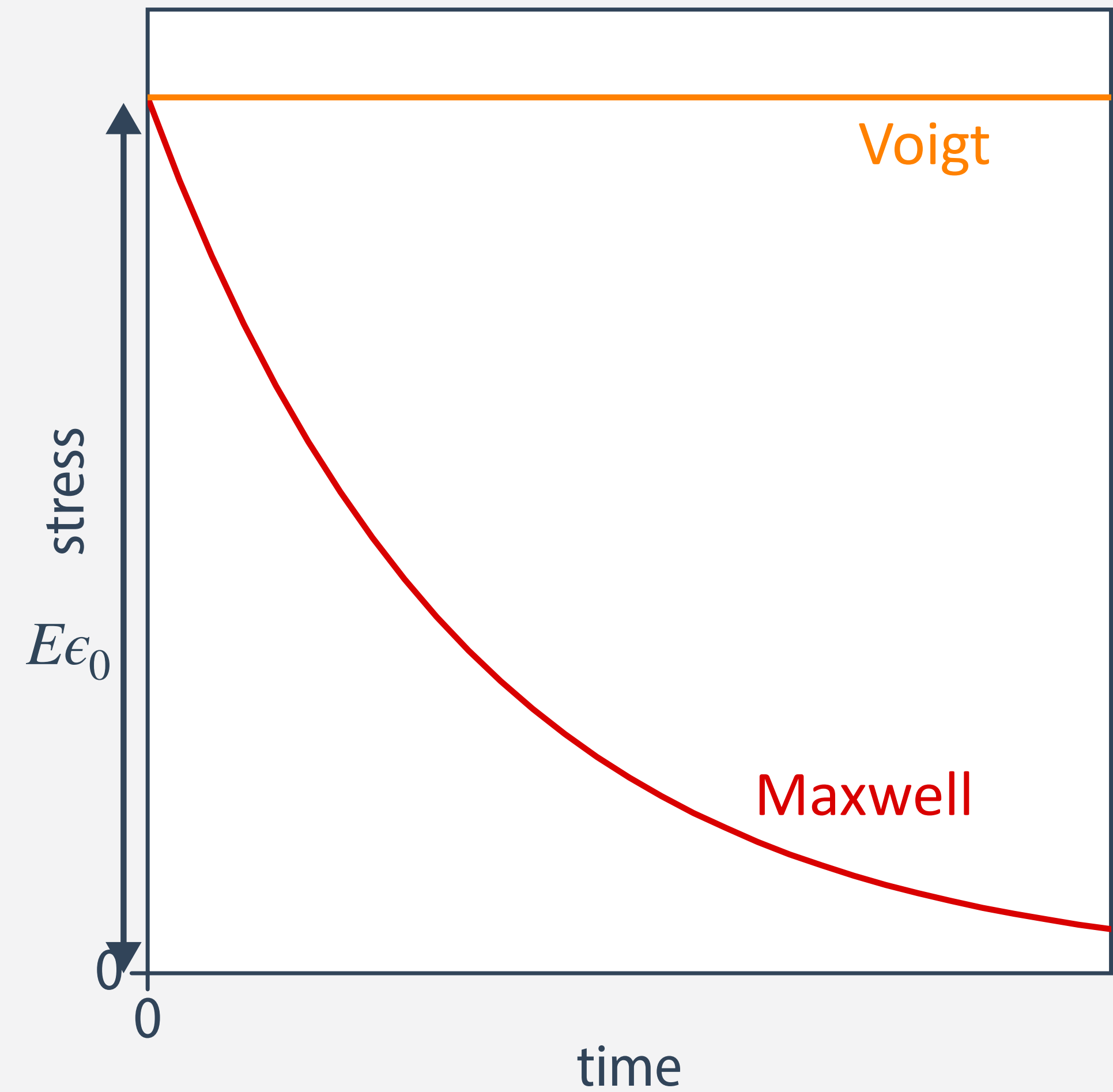

# Three Element Models

- **Example: Zener model**

(combined Maxwell and Voigt elements)

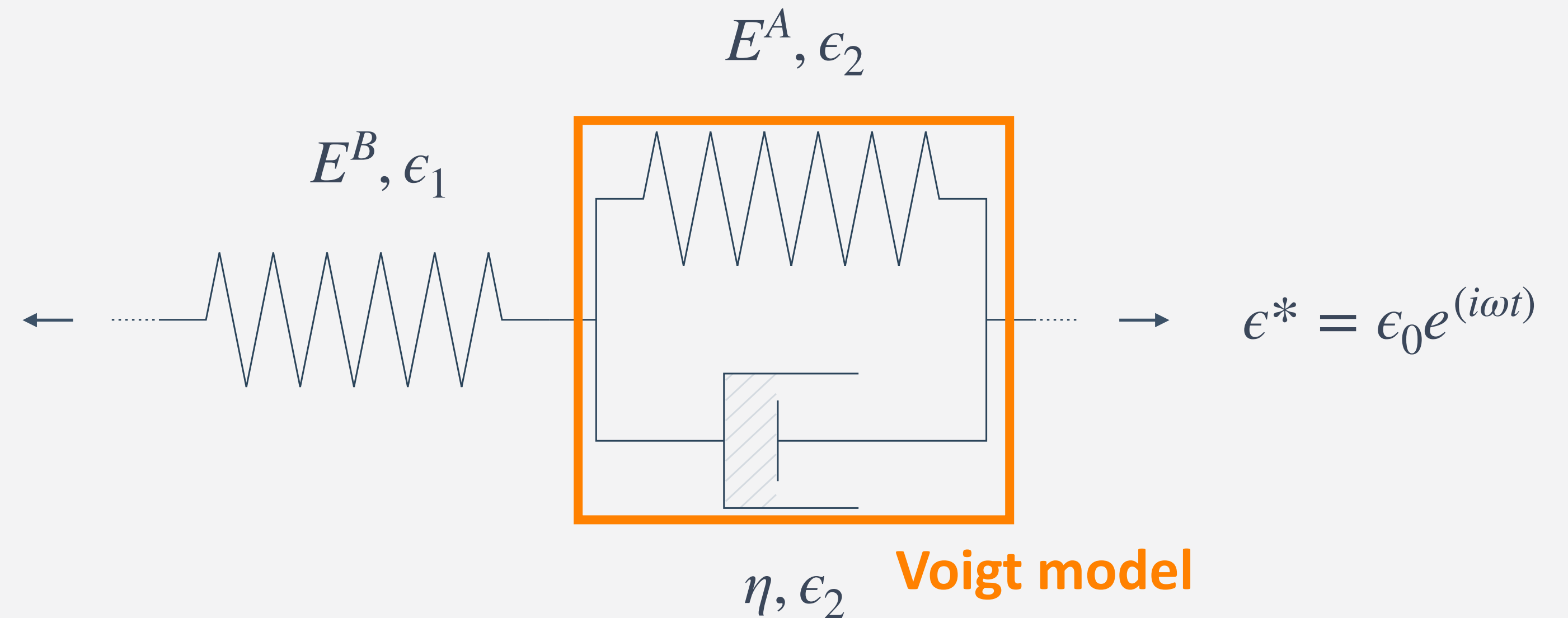

- **we use:**  $E_0 = E^B$        $E_\infty = \frac{E^A E^B}{E^A + E^B}$        $\tau_\delta = \frac{\eta(E_0 - E_\infty)}{E_0^2}$

- **after some calculations, we find:**

$$E' = E_0 - \frac{E_0 - E_\infty}{1 + (\omega\tau_\delta)^2} \qquad E'' = \omega\tau_\delta \frac{E_0 - E_\infty}{1 + (\omega\tau_\delta)^2} \qquad \tan(\delta) = \frac{\omega\tau_\delta(E_0 - E_\infty)}{\sqrt{E_0 E_\infty} (1 + (\omega\tau_\delta)^2)}$$

# Basic Mechanical Behavior

## Zener model

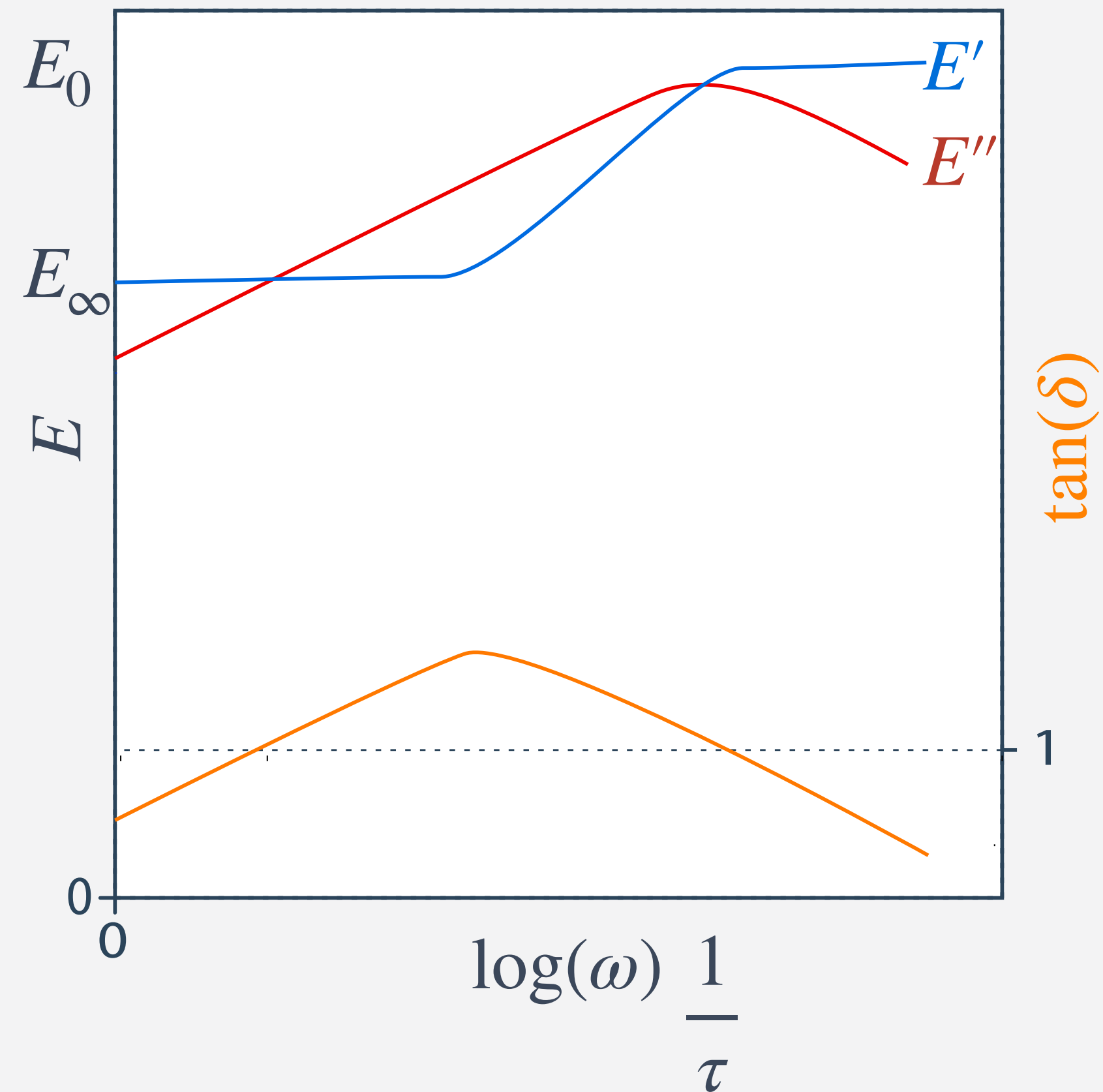

## real polymers

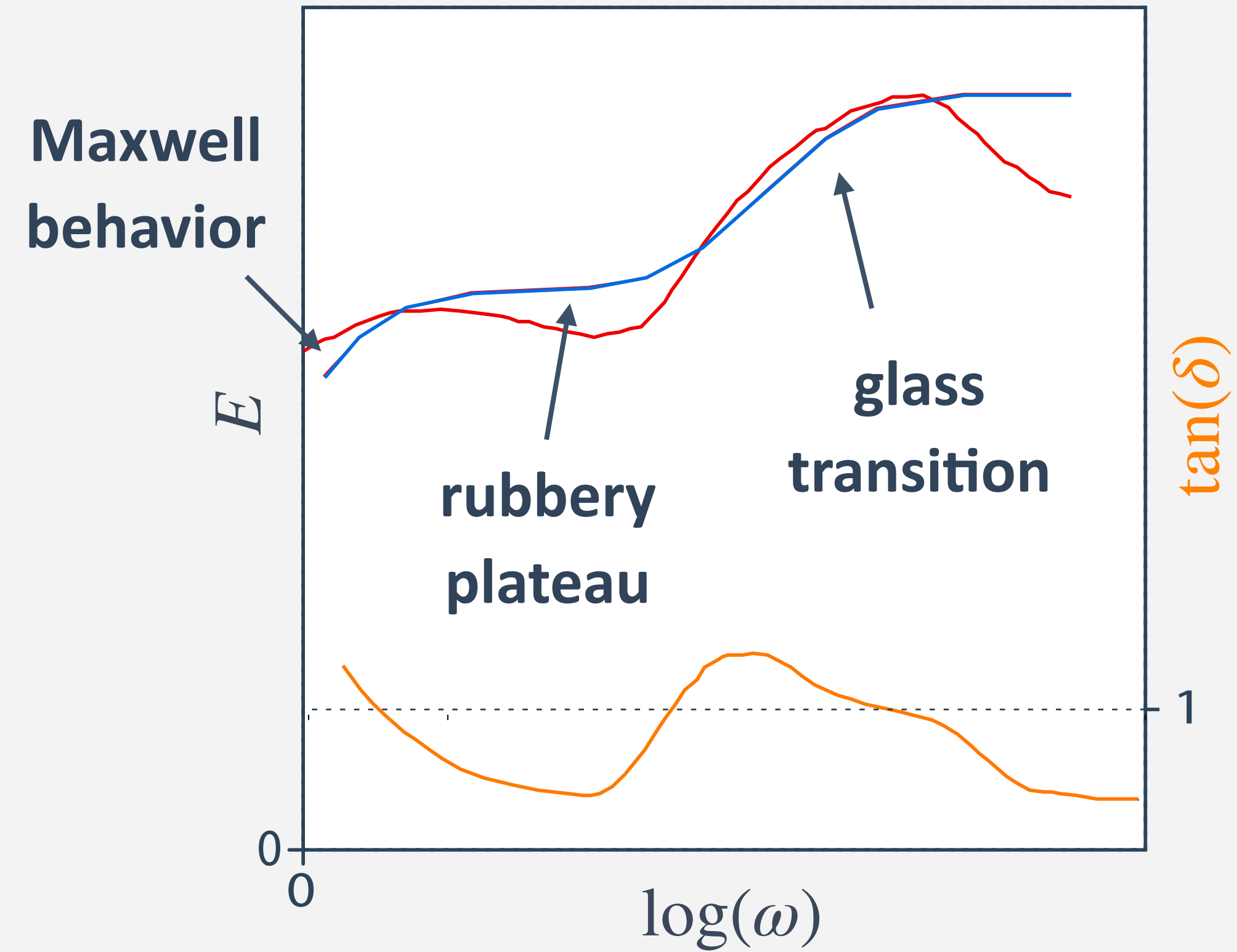

- $E''$  always peaks at the glass transition
- $E' \rightarrow E_0$  for  $\omega \ll 1/\tau_\delta$ , equals Maxwell model when  $E^A = 0$

# Generalised Voigt-Maxwell Model

- multiple relaxation times describe more realistic behavior:

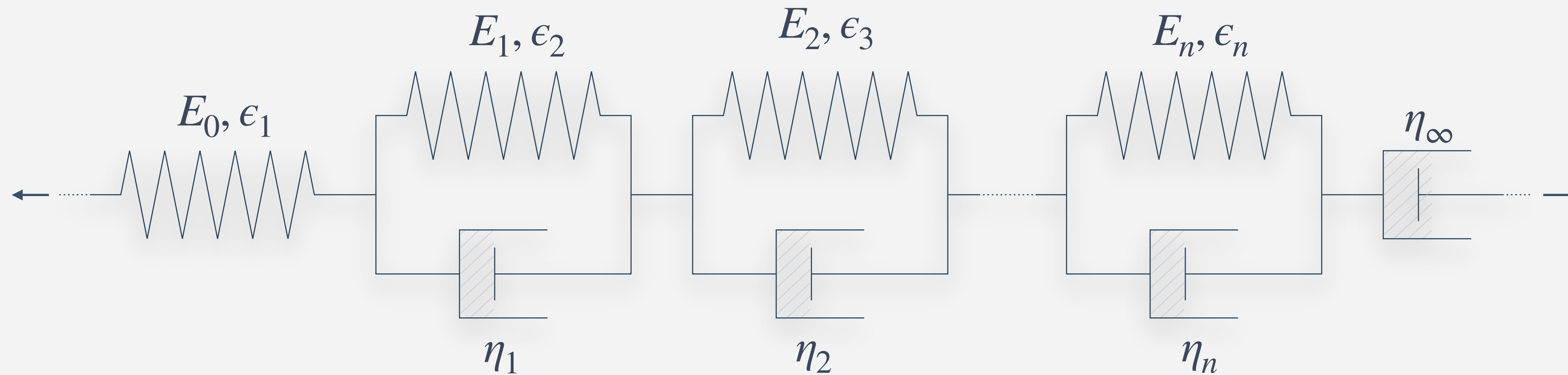

$$E(t) = E_{\infty} + \sum_1^n E_i e^{(-\frac{t}{\tau_i})}$$

- for continuous conditions, we get the relation to a relaxation time spectrum  $H(\tau)$ :

$$E(t) = E_{\infty} + \int_{-\infty}^{\infty} H(\tau) e^{-\frac{t}{\tau}} d \ln \tau$$

# Generalised Voigt-Maxwell Model Under Dynamic Conditions

$$G(t) = \sum_{i=1}^N G_i e^{-\frac{t}{\tau_i}}$$

$$G'(t) = \sum_{i=1}^N G_i \frac{(\omega\tau_i)^2}{1 + (\omega\tau_i)^2}$$

$$G''(t) = \sum_{i=1}^N G_i \frac{\omega\tau_i}{1 + (\omega\tau_i)^2}$$

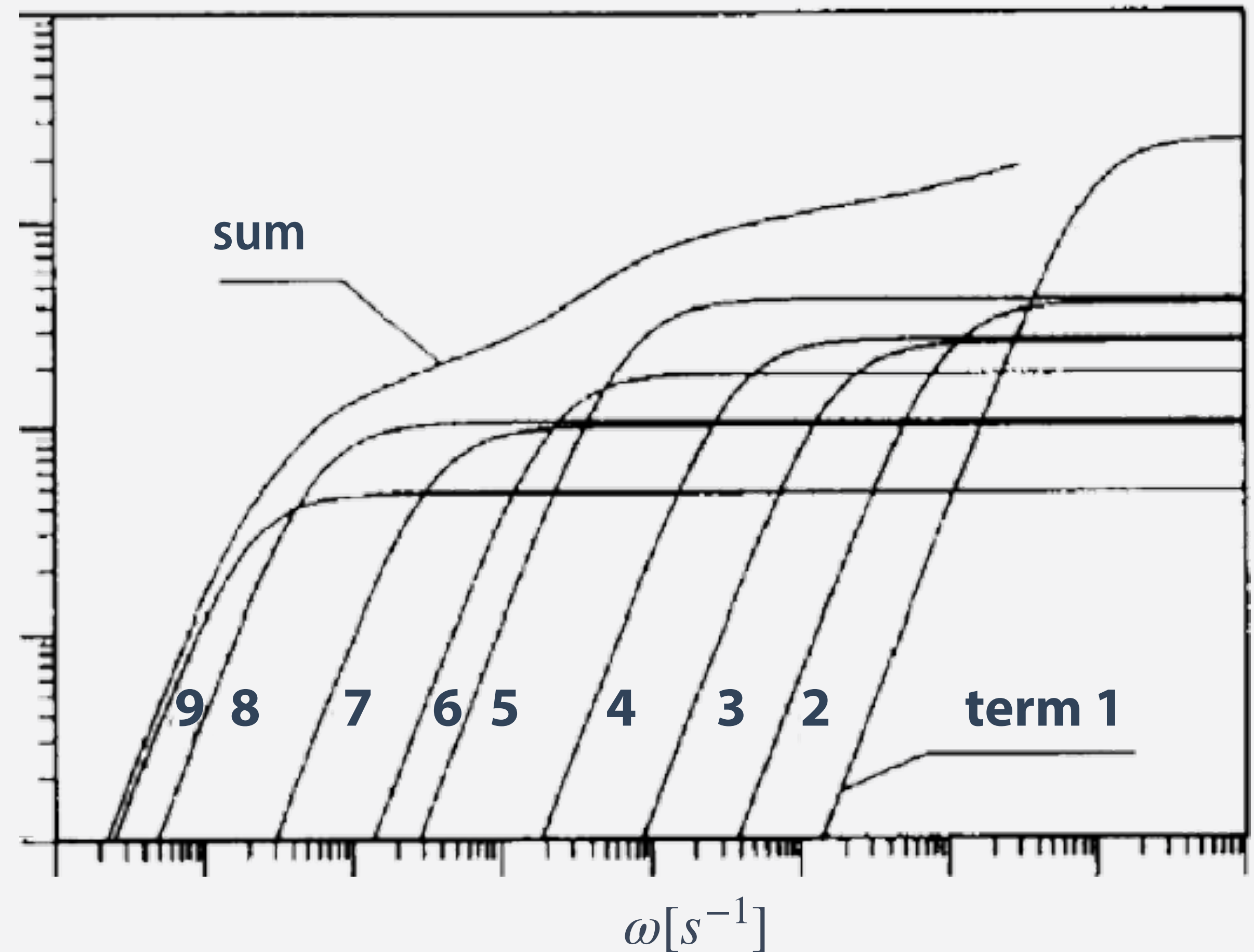

- low-frequency behavior dominated by the longest relaxation time  $\tau$
- $G_i$  and  $\tau_i$  are empirical, often with limited physical meaning

# Time-Temperature Equivalence

# Time-Temperature Equivalence

- increasing **temperature** or **time** (or decreasing **frequency**) produces similar effects on  $E$

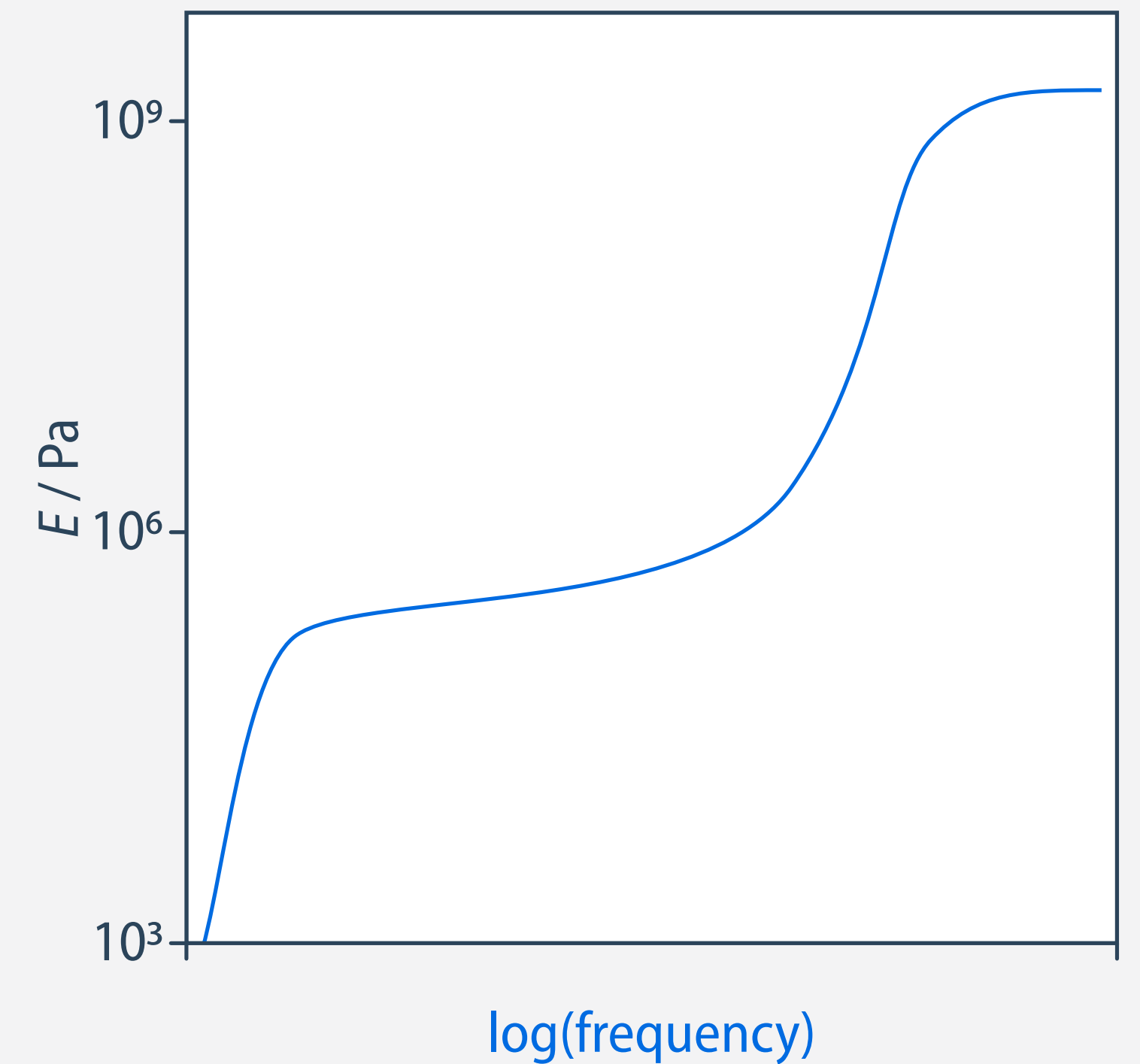
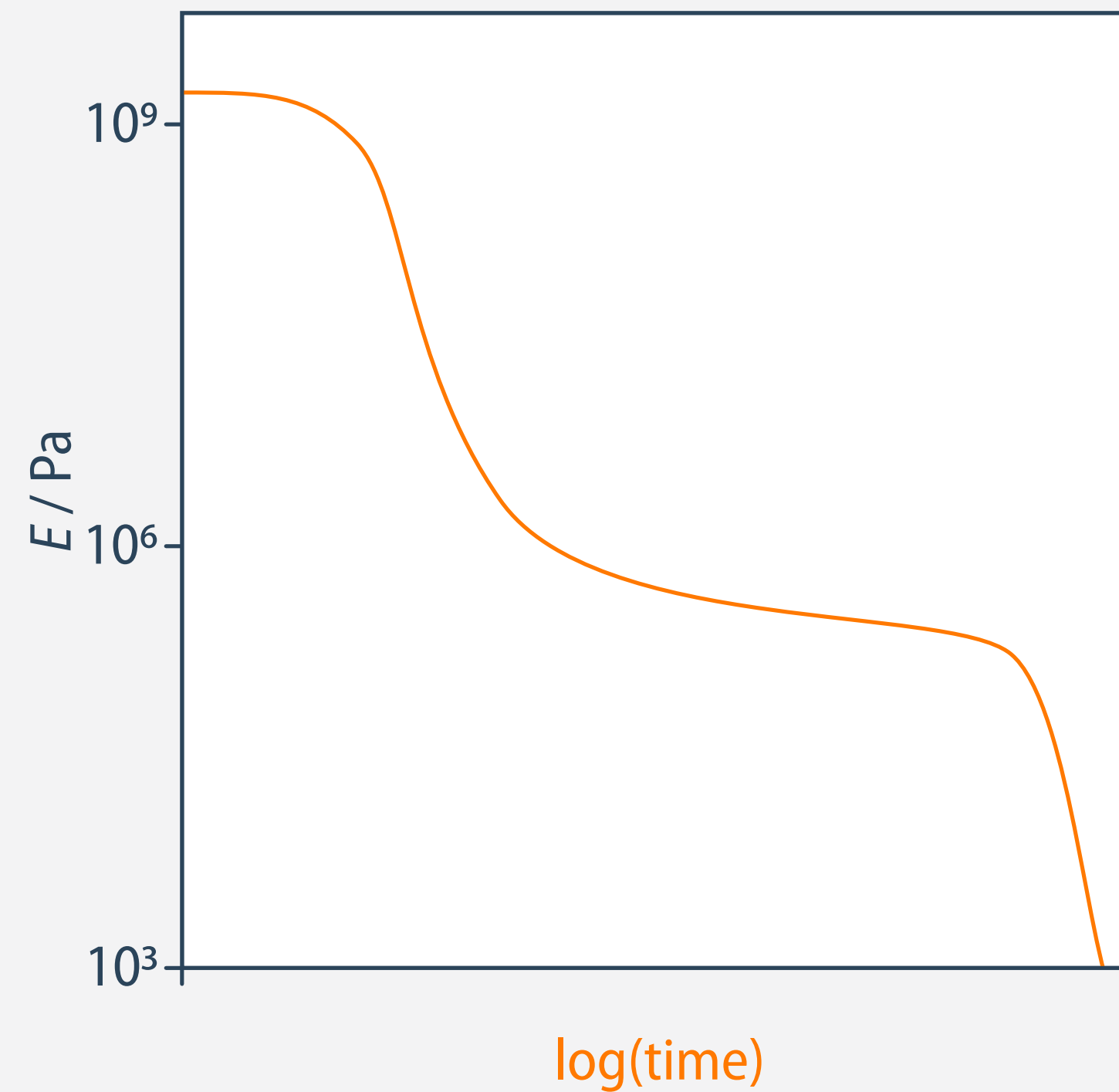
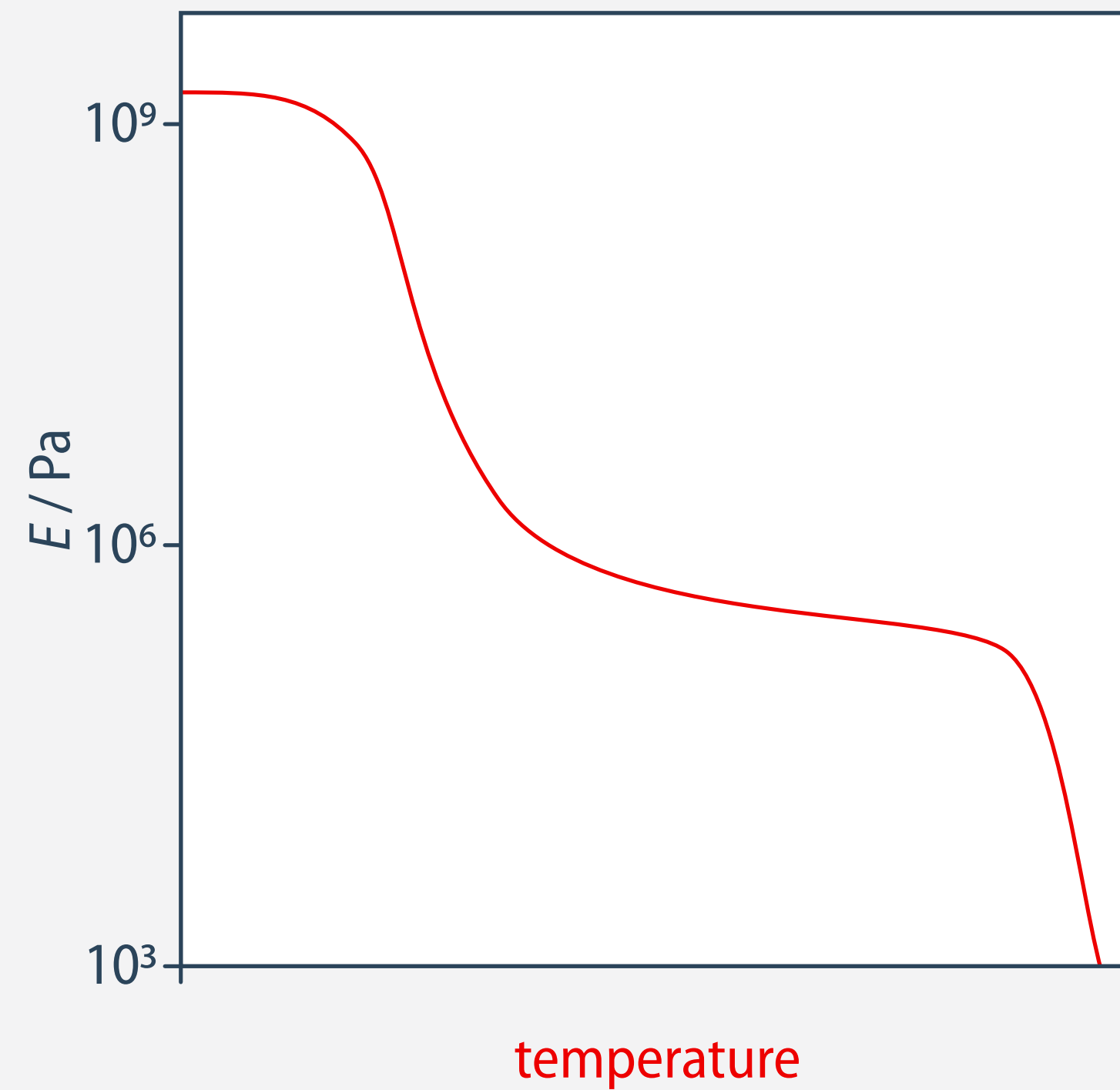

- can we relate time (or frequency) and temperature quantitatively?

# Time-Temperature Superposition

- measurements of  $E'$  as function of frequency at several temperatures

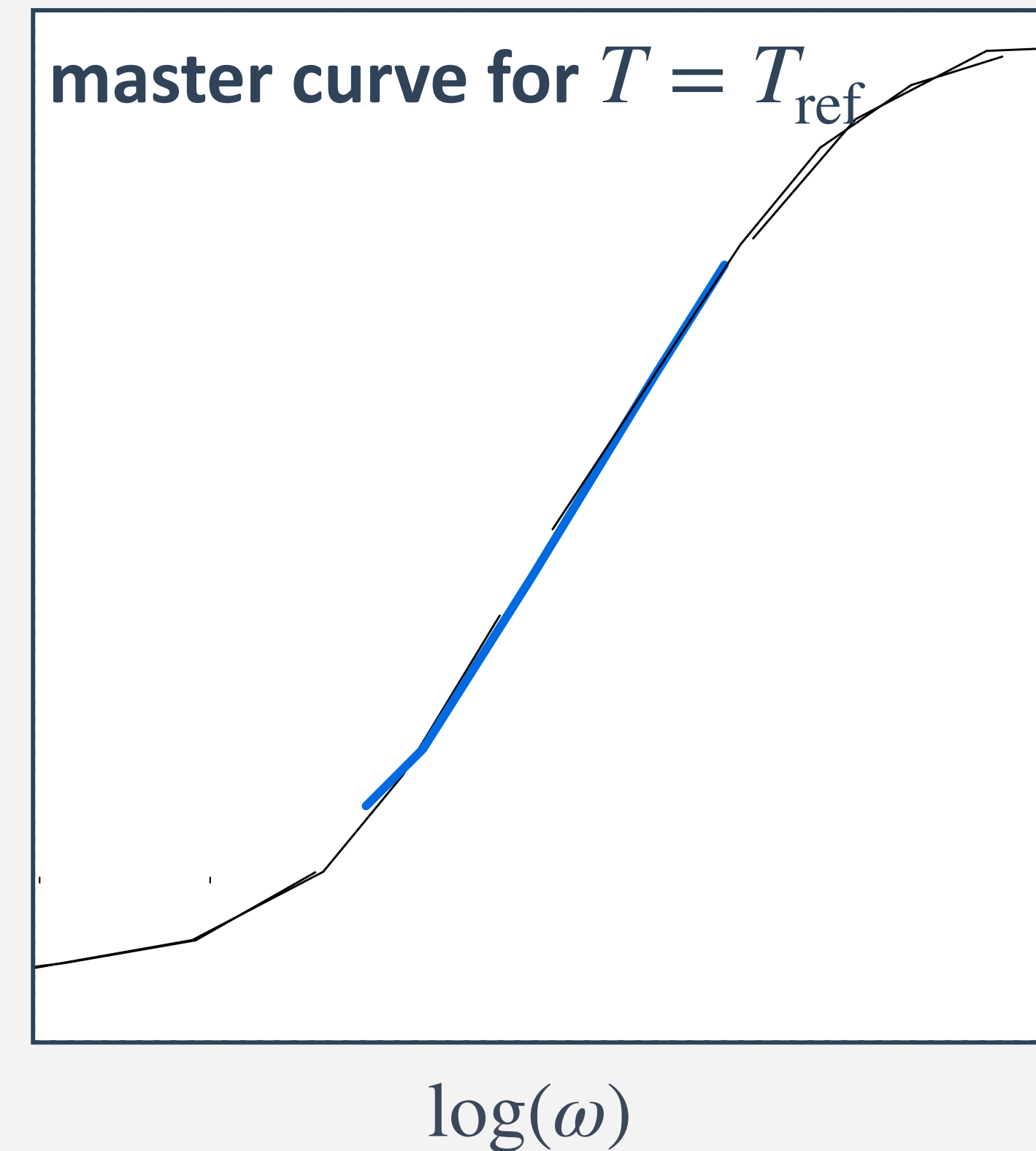
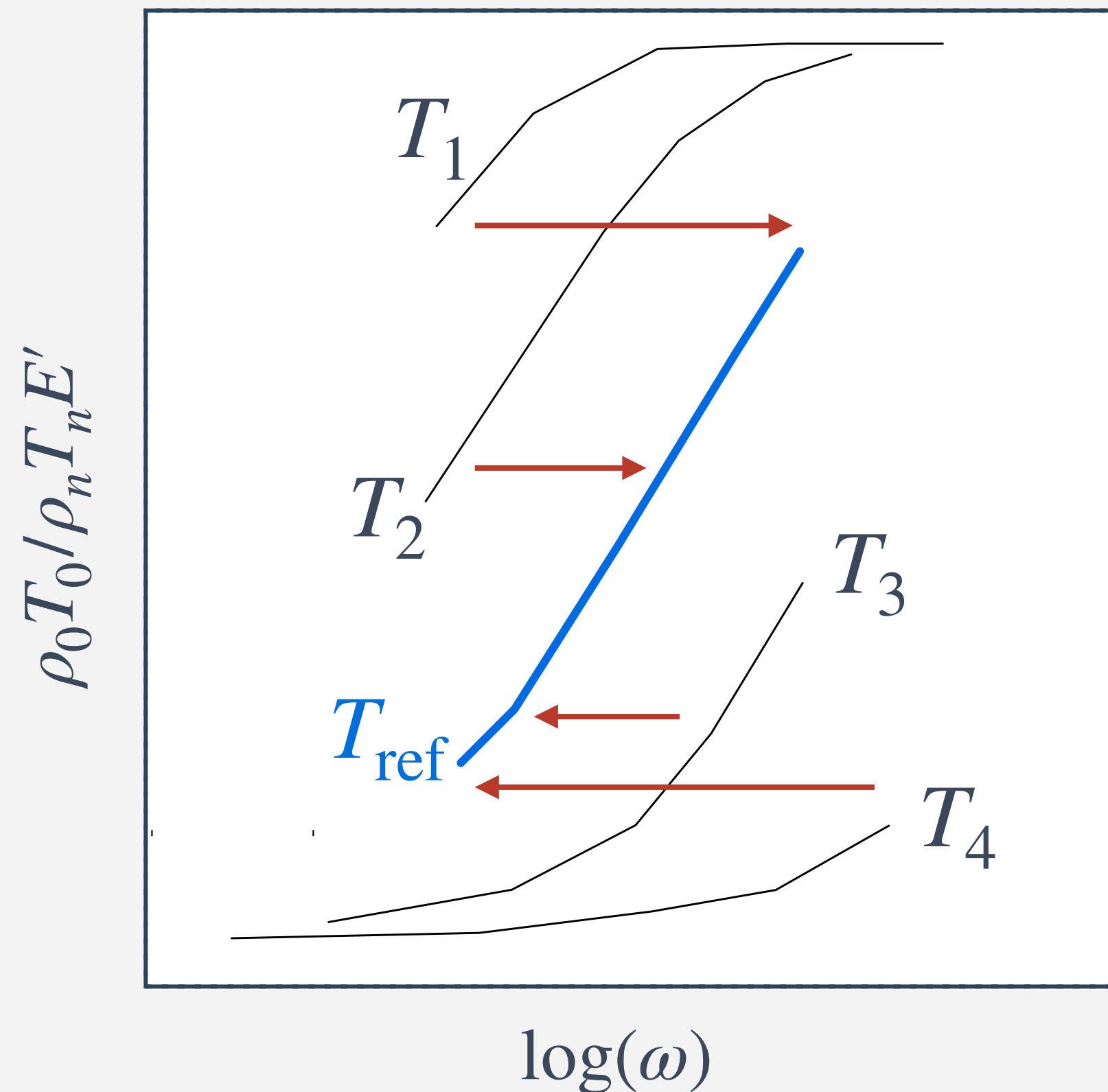

- after correction for  $\rho T$ , superimposed curves by horizontal shifts along  $\log(\omega)$  to form a master curve
- extends the accessible frequency range

# Williams-Landel-Ferry (WLF) Equation

- shift factors follow the empirical WLF relation:

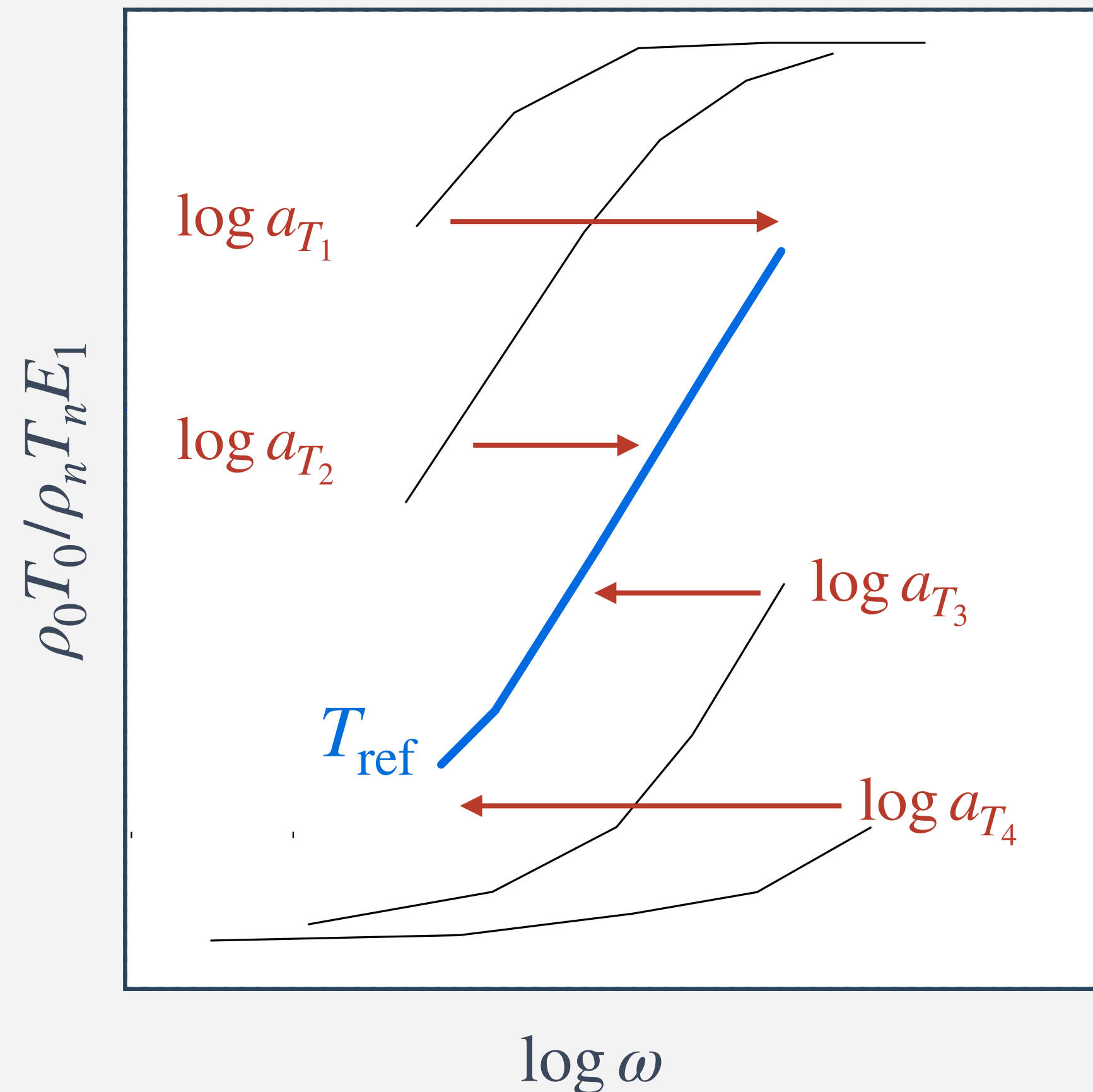

$$\log(a_T) = \log(\omega_{\text{ref}}) - \log(\omega) = \log\left(\frac{\omega_{\text{ref}}}{\omega}\right)$$

$$\log(a_T) = -\frac{C_1(T - T_{\text{ref}})}{C_2 + T - T_{\text{ref}}}$$

for  $T_{\text{ref}} = T_g$ :

$$\log(a_T) = -\frac{17.44(T - T_{\text{ref}})}{51.6 + T - T_{\text{ref}}}$$

- using  $T_g$  as reference temperature gives near-universal constants  $C_1 = 17.44$  and  $C_2 = 51.6$  K

# Interpretation by Free Volume Theory

- the WLF equation, though empirical, can be justified by free volume considerations:

- from free Volume Theory:  $\tau(T) = \tau_0 e^{\frac{v_0}{v_f}} = \tau_0 e^{\frac{\Delta\alpha^{-1}}{T-T_0}}$  see Slide 152

- let  $T_0 = T_g - A$ ,  $\tau(T) = \tau_0 e^{\frac{\Delta\alpha^{-1}}{A+T-T_g}}$ ,  $\tau(T_g) = \tau_0 e^{\frac{\Delta\alpha^{-1}}{A}}$ :

- we saw:  $a_T = \frac{\omega(T_g)}{\omega(T)} = \frac{\tau(T)}{\tau(T_g)}$   $\ln a_T = \ln \tau(T) - \ln \tau(T_g) = \frac{\Delta\alpha^{-1}}{A+T-T_g} - \frac{\Delta\alpha^{-1}}{A}$

$$\ln a_T = -\frac{A^{-1}\Delta\alpha^{-1}(T-T_g)}{A+T-T_g} \quad \text{compare with the WLF equation:} \quad \log(a_T) = -\frac{C_1(T-T_{\text{ref}})}{C_2+T-T_{\text{ref}}}$$

# Analysis of Horizontal Shift Factors

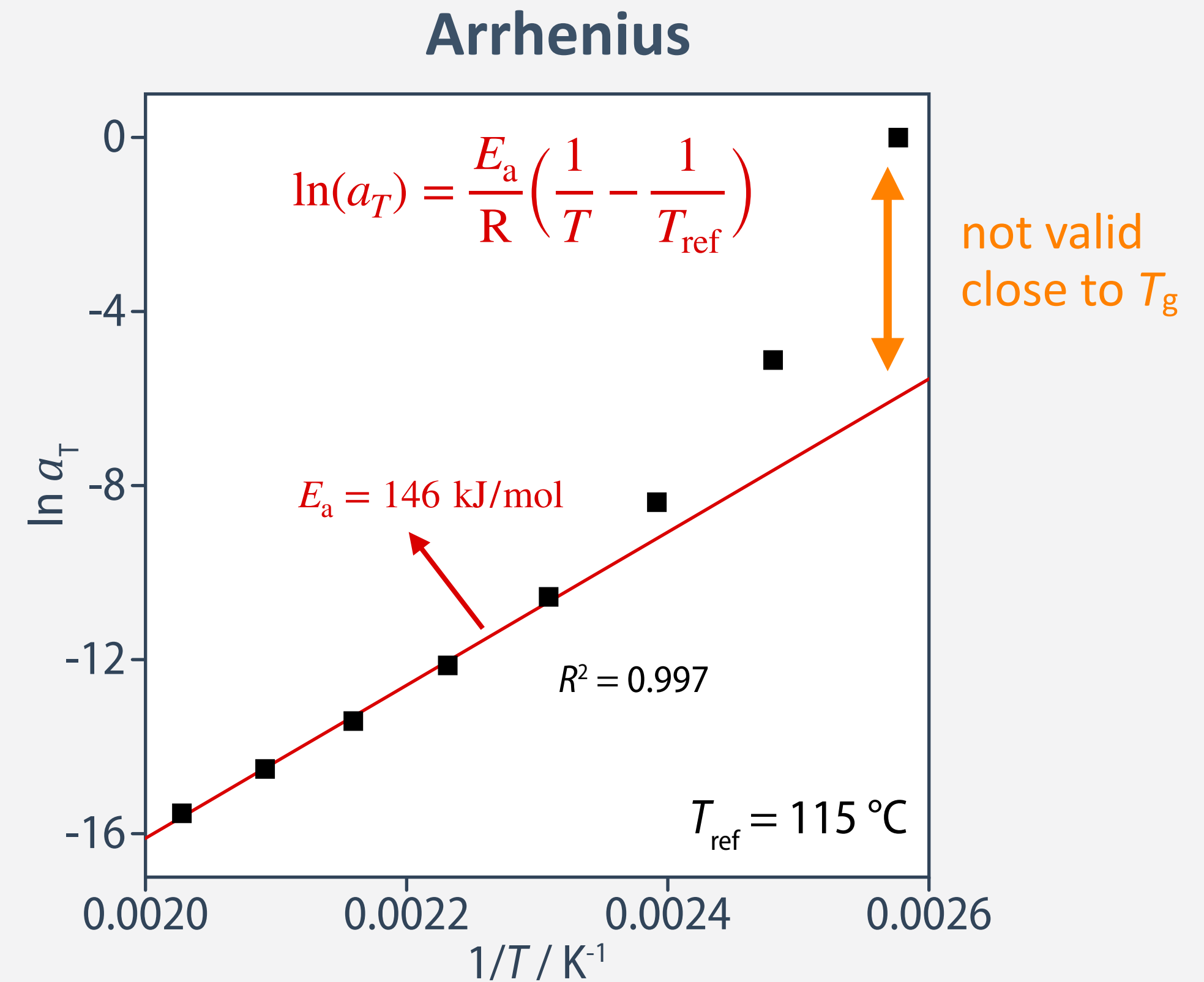
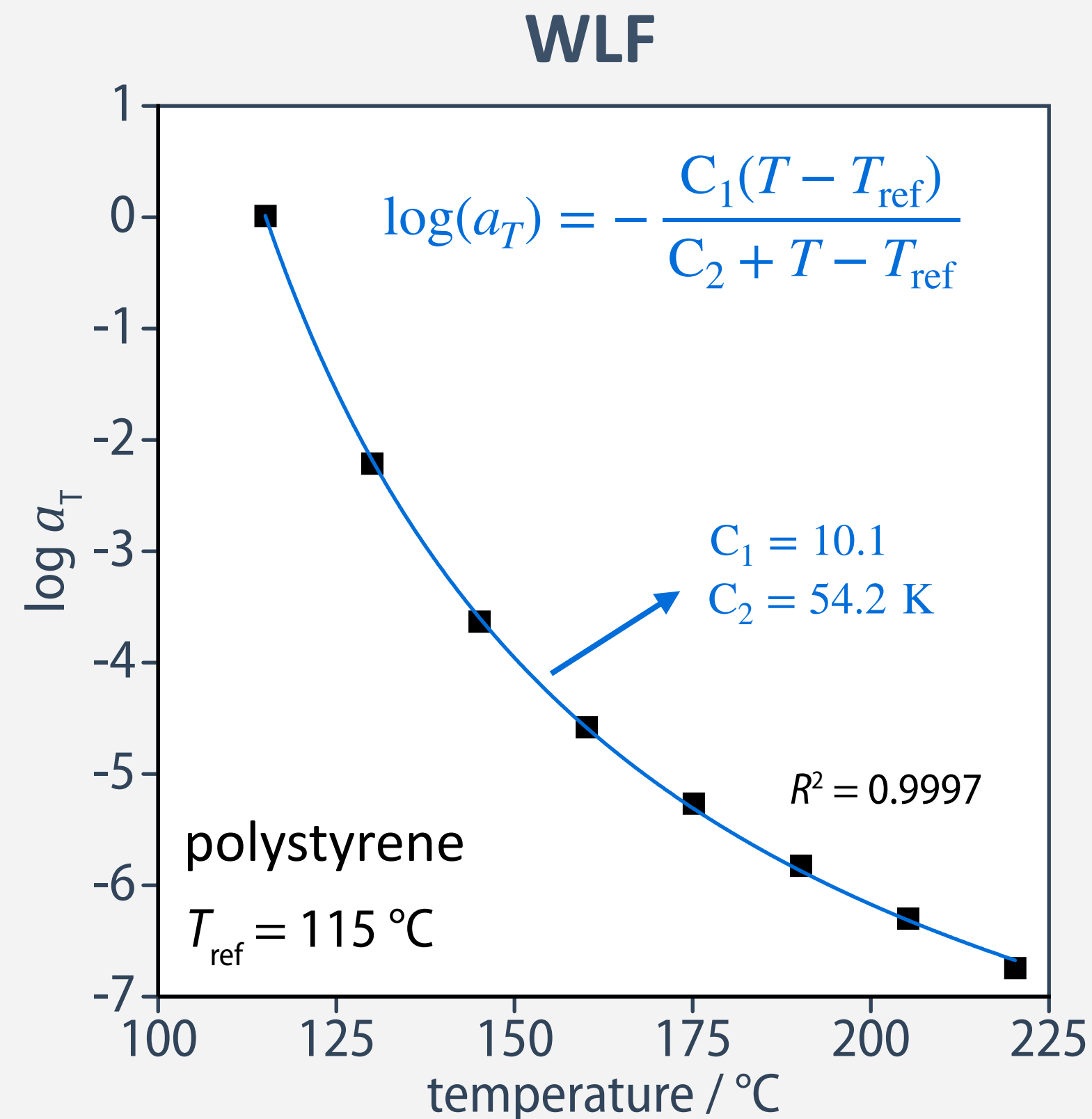

- **WLF plot: describes free-volume-controlled dynamics near  $T_g$**
- $C_1$  (“sensitivity to heating”) and  $C_2$  (“distance to the glass”) depend on  $T_{\text{ref}}$
- **Arrhenius plot: describes thermally activated conformational motion at high temperatures**

# Implications and Limitations of the WLF Equation

- Experimental time or frequency windows are limited: the WLF approach extends these ranges and enables prediction of long-term (creep) behavior.
- valid approximately for  $T_g < T < T_g + 50 - 100$  K
- deviations from “universal” constants are common and depend on  $T_{\text{ref}}$
- not applicable to non-linear behavior (large deformations)
- thermorheological simplicity required: all viscoelastic quantities ( $E'$ ,  $E''$ ,  $\tan(\delta)$ ) must shift by the same factor
- The WLF equation is an empirical yet powerful tool, best used within its valid window around  $T_g$

# Learning Outcome

- **polymers are viscoelastic materials, their mechanical response depends strongly on the timescale of the measurement.**
- **linear viscoelasticity applies for small deformations, enabling simple mechanical models to describe time-dependent behavior.**
- **time-temperature equivalence is a hallmark of polymer dynamics: it justifies time-temperature superposition, which allows extending measurements across otherwise inaccessible time or frequency ranges.**